

C | Range

Metering pumps



You are at the **centre**
of everything we do

This is **who** we are

Rotary Power specialises in the design, development and manufacture of hydraulic pumps and motors. With a history dating back over 50 years we understand the exacting and demanding requirements of today's hydraulic applications.

Our current product range includes :

"A" Axial Piston Pumps for heavy-duty open circuit applications. Wide range of controls. Excellent life characteristics. Suitable for most fluids, including HLP, HFA, HFB, HFC, HFD, HFR, HFE, Isocyanates and Polyols. Fixed and variable capacities from 11.5 to 125 cm³/rev.

"C" Axial Piston Pumps for high accuracy fluid metering with precision flow controls and high-pressure capability. Specifically designed for the Polyurethane Industry. Capacities from 2 to 62 cm³/rev.

"XL" Cam Motors of radial piston configuration. Wheel/shaft/torque module configurations. Design offers high-speed capability. Capacities from 150 to 1120 cm³/rev.

"XK" Cam Motors radial piston configuration offering static/dynamic brakes, single or 2 speed, wheel/shaft and torque module mount options. Heavy-Duty External Load & High-Speed options. Capacities from 1000 to 5000 cm³/rev.

"SMA" Motors heavy-duty radial piston/eccentric configuration, offering excellent life. Withstands high mechanical and hydraulic shock loads. 350bar Continuous pressure rating. Speed & power ratings significantly greater than standard HTLS motors. Displacements from 150 to 10500 cm³/rev.

Wholly owned subsidiaries in the USA and Germany and a network of distributors throughout the world provide product support in most countries.

Rotary Power was established over 50 years ago and is part of the British Engines group.

The British Engines group of companies design manufacture and market a wide range of engineered products for offshore, electrical, construction, engineering and other industries, employing over 1,000 people in North East England.

Features

- Designed specifically for the Polyurethane foam industry from over 20 years application experience and development.
- Uniform fluid temperatures throughout the pump.
- Designed for high inlet pressure. Twin PTFE seals running on a ceramic bush allow up to 20 bar.
- High metering accuracy. Matched and balanced control components minimise backlash errors.
- No leakage return line, pump is internally drained.
- Leakage indicator and lubrication ports included
- All major components treated to minimise corrosion.
- Cartridge shaft seal to ease service and minimise maintenance time.
- Certified to ATEX directive 94/9/EC

C Range **metering pumps** for P.U. foam production

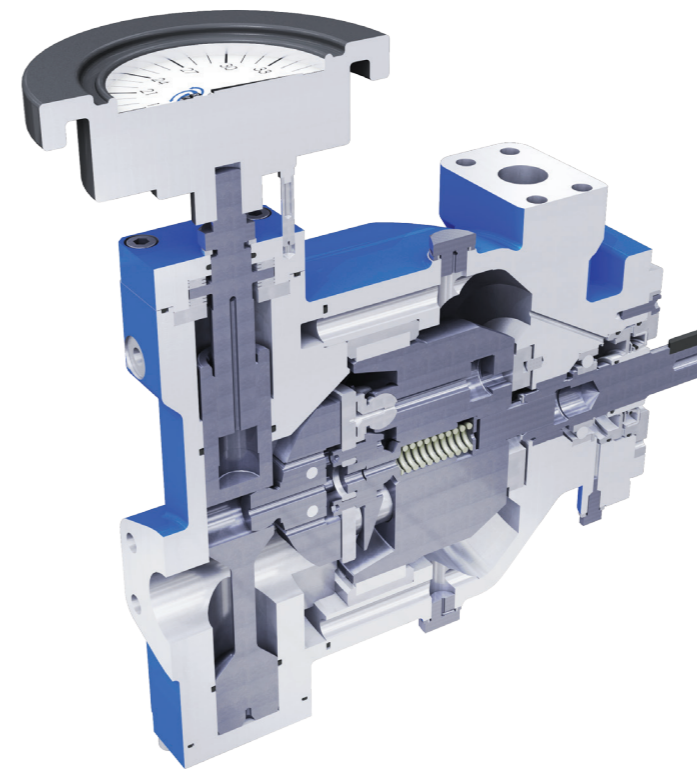

Foreword

Rotary Power have supplied pumps to the Urethane foam industry for over 40 years'.

This catalogue sets out the most commonly required information for successful application and reliable use of C range pumps. Further advice and assistance is readily available from our engineers.

Contents

Technical Data	2-3
Performance Data	4-5
Installation Data - MD	6-7
Installation Data - FA	8-9
Pump Application	10-11
Commissioning & Installation	12
Accessories	13
Ordering Code	13

Type	Description
FA	Fixed displacement.
MB	Variable displacement manual, fine adjustment with plain handwheel.
MD	Variable displacement manual, fine adjustment with dial indicator handwheel.
ME	Variable displacement manual, fine adjustment, spindle only.

Technical data

Technical data

Pump Range		C-Range				
SEE NOTE	Model	C01	C04	C07	C20	C38
	Geometric displacement (cc/rev)	2	6	11.5	33	62
1	Maximum speed rev/min	1800	1800	1800	1800	1800
2	Minimum speed rev/min	200	200	200	200	200
3	3 Max outlet pressure TDI (bar)	210	210	210	210	210
3	Max outlet pressure MDI, polyol (bar)	250	250	250	250	250
4	Min outlet pressure (bar) above inlet	2	2	2	2	2
5	Max inlet pressure (bar)	20	20	20	20	20
	Min inlet pressure (bar)	See Graph 2				
	Max viscosity	2000 cSt, for higher viscosities consult ROTARY POWER				
	Min Viscosity	1 cSt				
6	Recommended fluid cleanliness	ISO/DIS 4406 Polyol ISO code 18/13 Isocyanate code 16/11				
	Max temperature	80°C				
	Optimum Temperature	10 to 50°C				
	Approximate weight (Kg)	16	18	20	30	40

Notes for technical data table

- Maximum allowable speed reduces for high viscosity fluids. Refer to Graph 1.
- Minimum speed is determined by flow stability.
- Pressures shown are for fluids complying with cleanliness codes stated in this table.
- Outlet pressure must never fall below inlet pressure this includes during stationary and start up conditions.

5. Inlet pressure should be kept to the minimum value possible, based on the characteristics of the fluid and other factors - see application section.

6. These recommendations for fluid cleanliness are made, based on the minimum conditions for optimum life. Like any mechanical component, normal wear will be accelerated either, by poor filtration and contaminated fluid or, by the use of abrasive substances such as "carbon black".

Graph 1

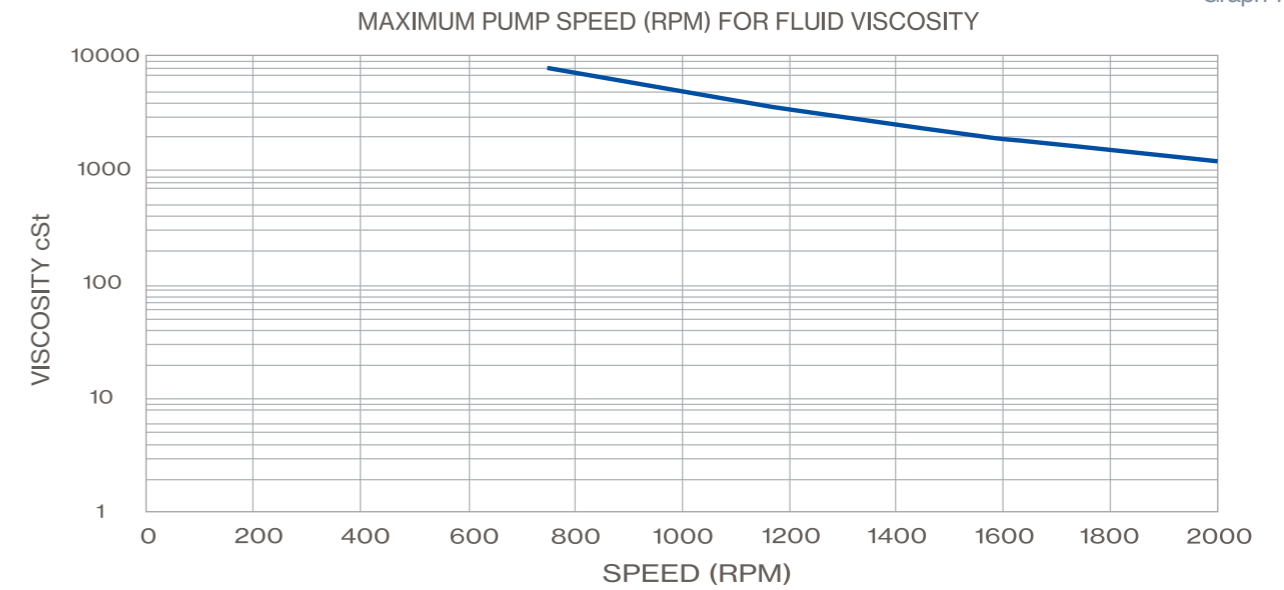

Graph 2

C PUMP MINIMUM BOOST REQUIREMENT (1500 rpm) AND MINIMUM DISCHARGE PRESSURE

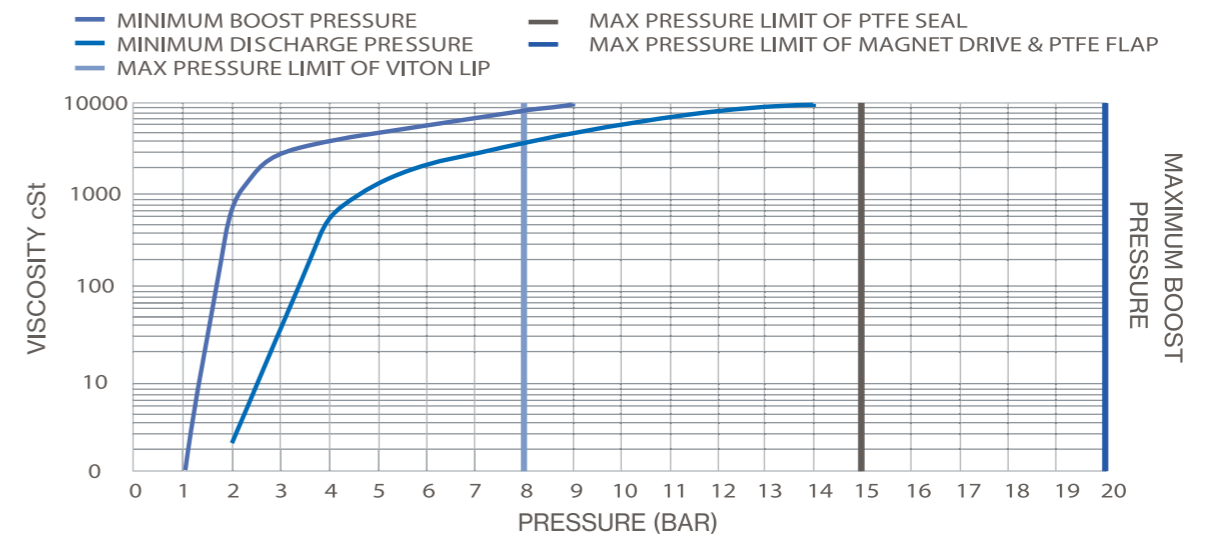

Graph 3

GUIDE TO PUMP SELECTION

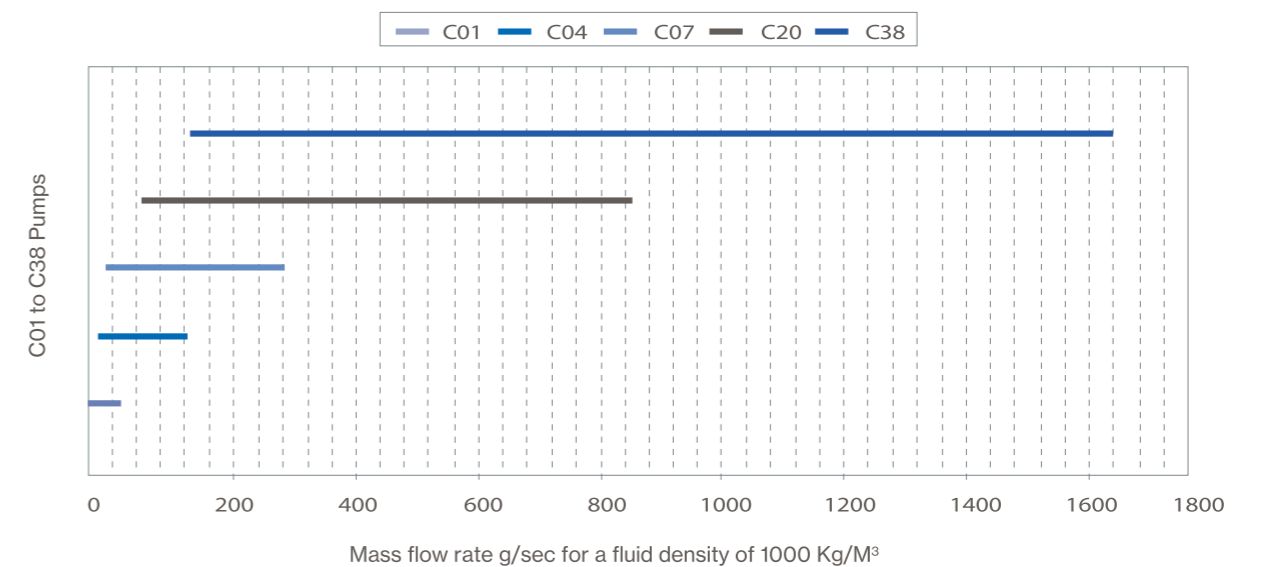

Performance Isocyanate

C range performance data isocyanate

The graphs shown on this page indicate discharge flows at 1500rpm, various swash angles on Isocyanate Fluid (2000 cSt).

Note: Figures shown do not include power loss when using magnetic drives.

C01 Delivery vs pressure Isocyanate

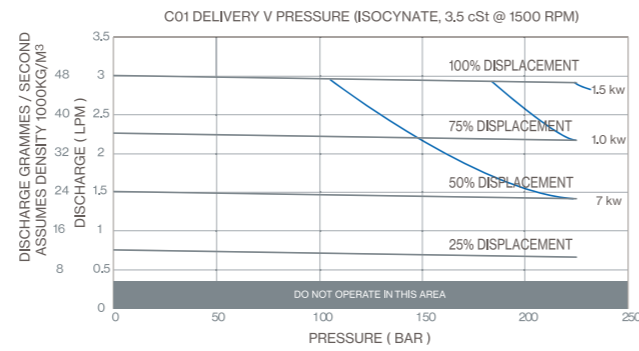

C04 Delivery vs pressure Isocyanate

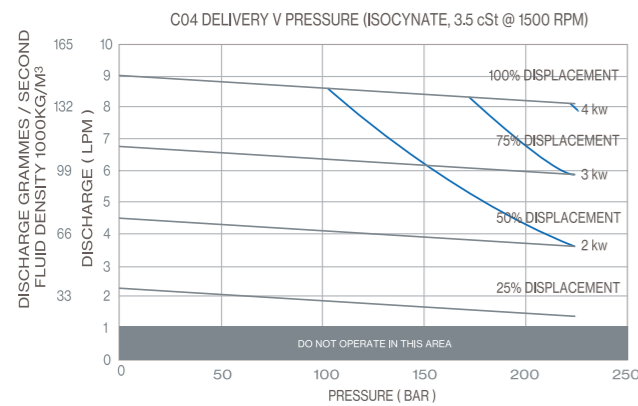

C07 Delivery vs pressure Isocyanate

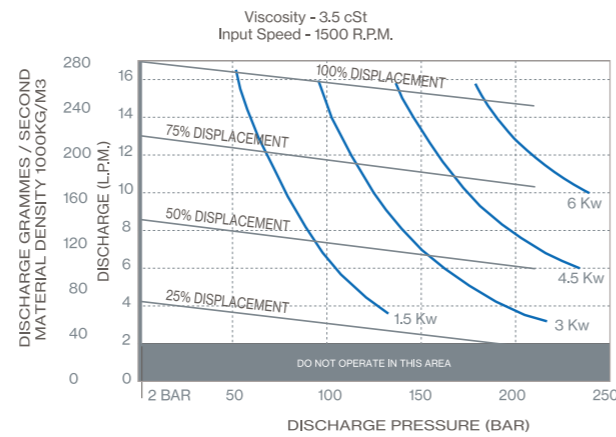

C20 Delivery vs pressure Isocyanate

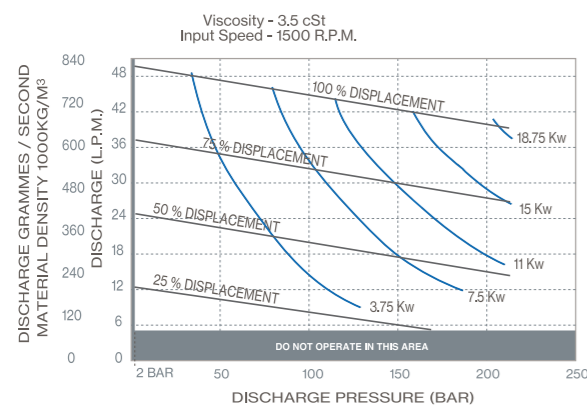

C38 Delivery vs pressure Isocyanate

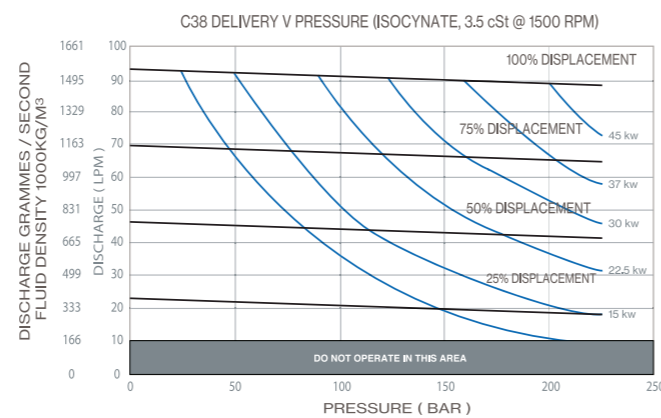

Performance Polyol

C range performance data Polyol

The graphs shown on this page indicate discharge flows at 1500rpm, various swash angles on Polyol Fluid (2000 cSt).

Note: Figures shown do not include power loss when using magnetic drives.

C01 Delivery vs pressure Polyol

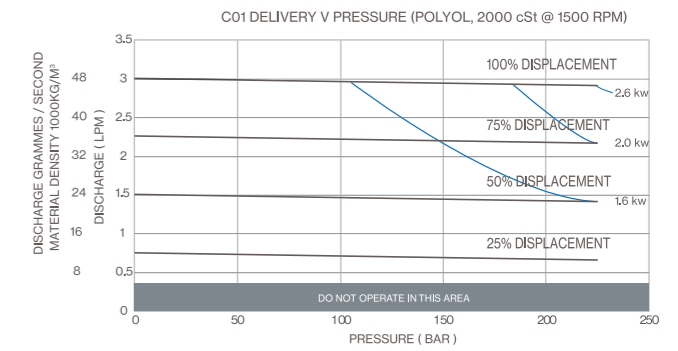

C04 Delivery vs pressure Polyol

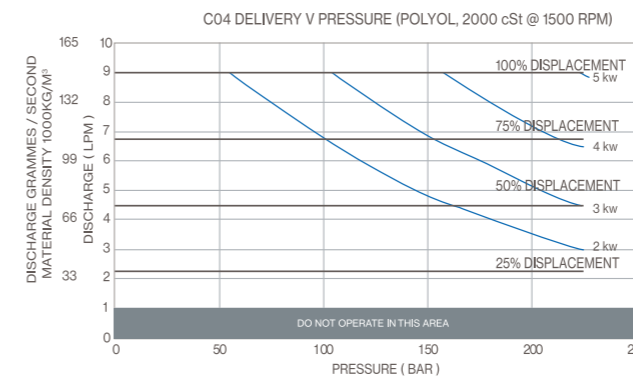

C07 Delivery vs pressure Polyol

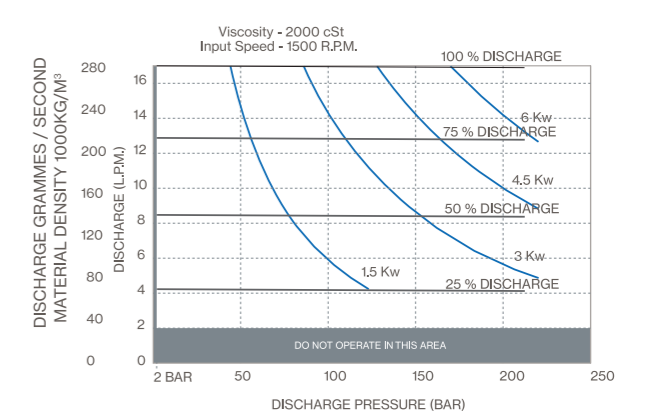

C20 Delivery vs pressure Polyol

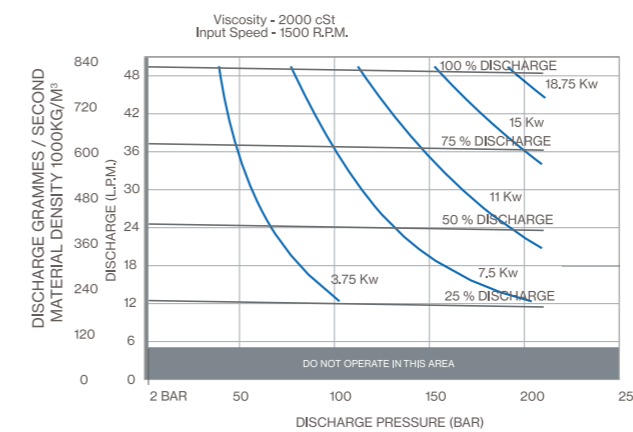

C38 Delivery vs pressure Polyol

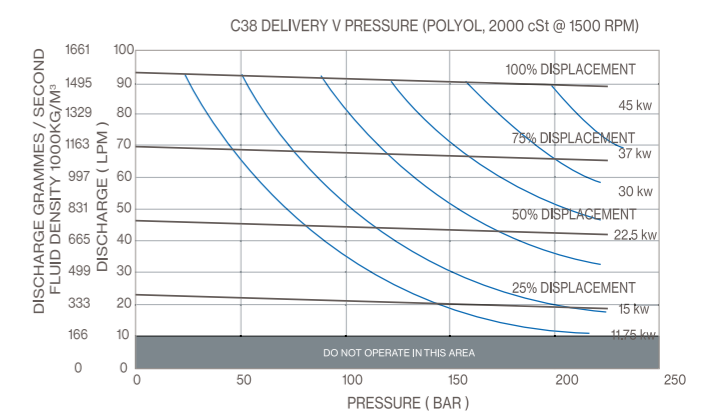

Installation drawings

C01 / C04 / C07 / C20 / C38 - MD

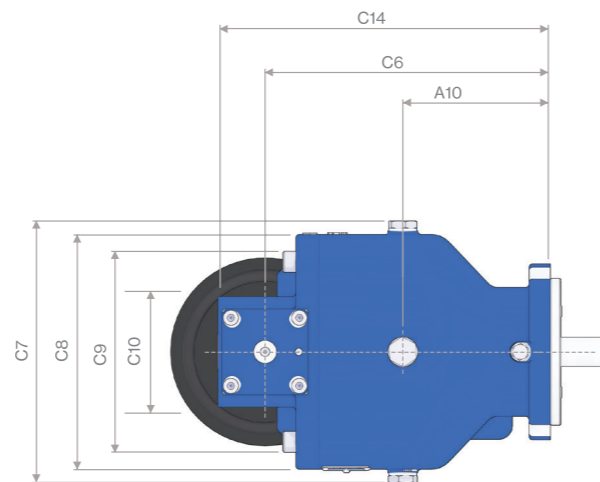
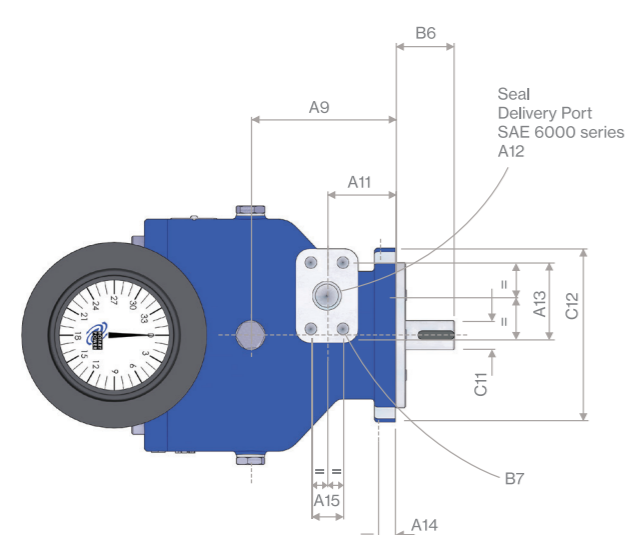
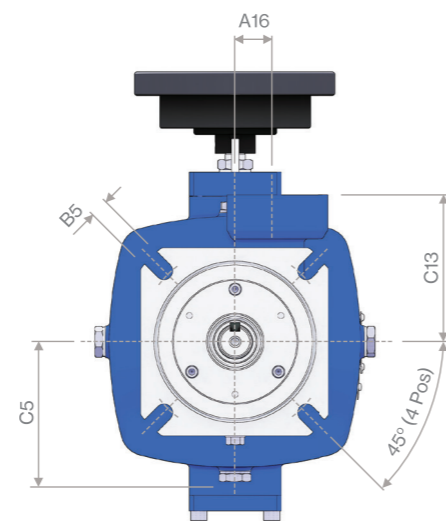
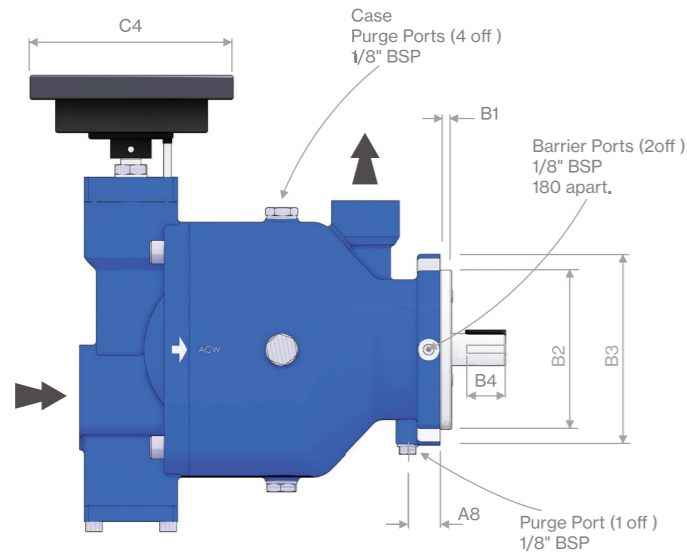
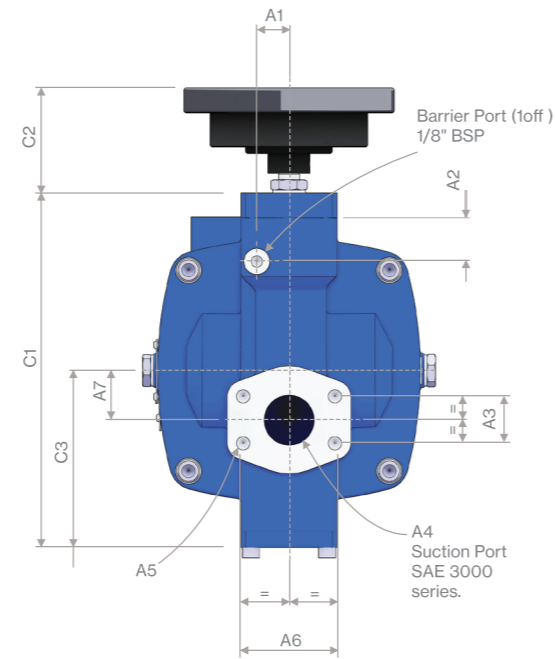

C01 Type

A1	A2	A3	A4	A5	A6	A7	A8	A9	A10	A11	A12	A13	A14	A15	A16
11	16.5	22.2	3/4"	M10 x 23	47.6	36	13	87	87	49	1/2"	40.5	9	18.24	12.5
B1		B2		B3		B4		B5		B6		B7			
8		80 h9		89.5		25 x 5		8.6		28		M8x20			
C1	C2	C3	C4	C5	C6	C7	C8	C9	C10	C11	C12	C13	C14	-	-
163	70	87	110	70	142	140-5	119	119	65	13	106	62	171	-	-

C04 Type

A1	A2	A3	A4	A5	A6	A7	A8	A9	A10	A11	A12	A13	A14	A15	A16
11	16.5	22.2	3/4"	M10 x 23	47.6	36	14	80	57	37	1/2"	40.5	9.6	18.24	17
B1		B2		B3		B4		B5		B6		B7			
8		80 h9		95.25		25 x 5		8.64		33.4		M8x20			
C1	C2	C3	C4	C5	C6	C7	C8	C9	C10	C11	C12	C13	C14	-	-
161	70	84.5	102	68.5	137.5	137	126	119.4	65	13	113	74.4	166.8	-	-

C07 Type

A1	A2	A3	A4	A5	A6	A7	A8	A9	A10	A11	A12	A13	A14	A15	A16
11	16.5	22.23	3/4"	M10 x 23	47.625	35.56	14	80	57	37	1/2"	39.38	9.6	18.24	17
B1		B2		B3		B4		B5		B6		B7			
9		80 h9		95.25		25 x 4.75		8.64		33.4		M8 x 20			
C1	C2	C3	C4	C5	C6	C7	C8	C9	C10	C11	C12	C13	C14	-	-
163	76	87	102	68.5	137.5	137	126	119.4	65	17.45 2	113	74.43	166.8	-	-

C20 Type

A1	A2	A3	A4	A5	A6	A7	A8	A9	A10	A11	A12	A13	A14	A15	A16
20	32	35.71	1.5"	M12x27	69.85	36	26.5	107	87	49.75	1"	57.15	10	27.76	30.9
B1		B2		B3		B4		B5		B6		B7			
8		100 h9		110		31.75 x 8		10.5		50.2		M12 x 27			
C1	C2	C3	C4	C5	C6	C7	C8	C9	C10	C11	C12	C13	C14	-	-
204.5	77	108	102	87.5	185	173	161	155	94	25.00	124	100	222	-	-

C38 Type

A1	A2	A3	A4	A5	A6	A7	A8	A9	A10	A11	A12	A13	A14	A15	A16
24.5	33	35.7	1.5"	M12 x 24	69.85	37.5	25.5	125	125	59	1"	57.15	9	27.76	34
B1		B2		B3		B4		B5		B6		B7			
9		125 h9		150		32 x 8		14		42.2		-			
C1	C2	C3	C4	C5	C6	C7	C8	C9	C10	C11	C12	C13	C14	-	-
269.5	80	134.5	160	111	242.7	223	200	200	73	25	150	117	282.7	-	-

Installation drawings

C01 / C04 / C07 / C20 / C38 - FA

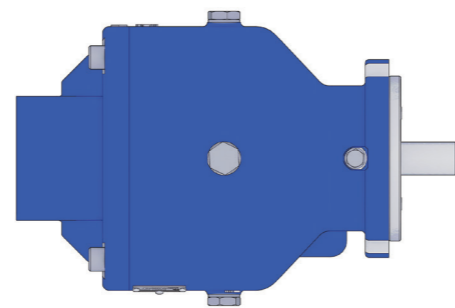
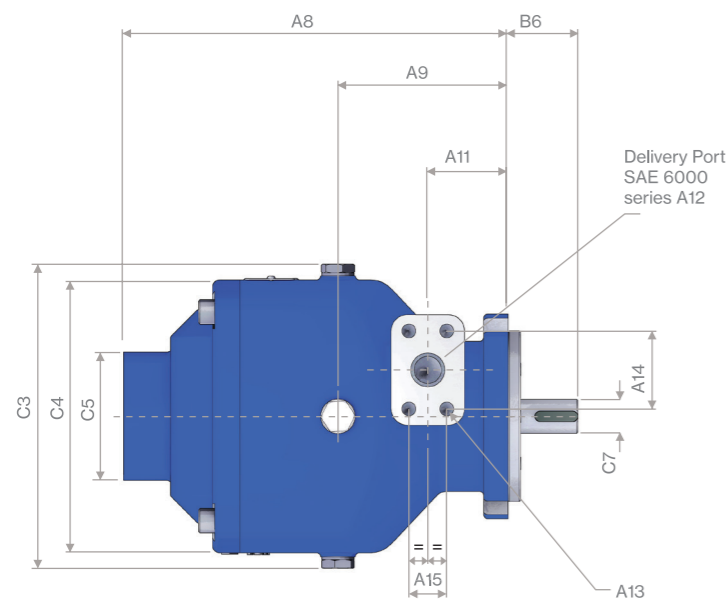
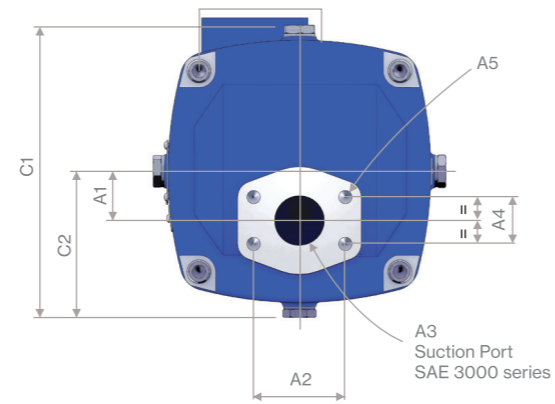
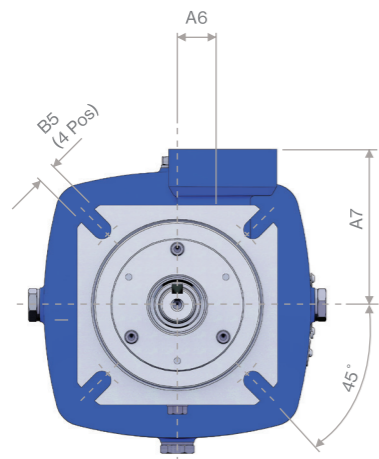
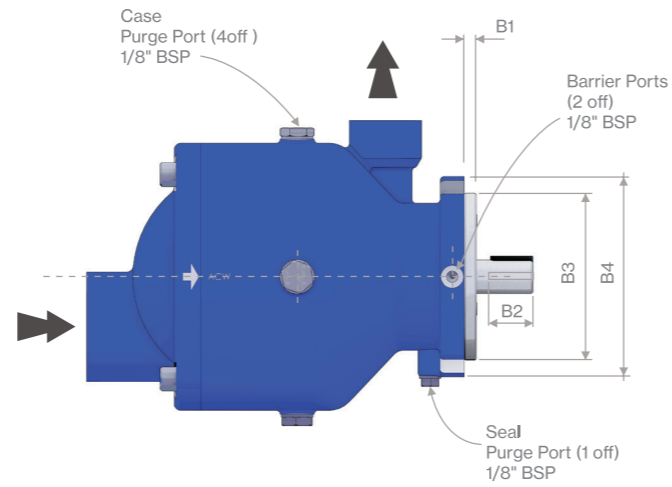

C01 Type

A1	A2	A3	A4	A5	A6	A7	A8	A9	A10	A11	A12	A13	A14	A15	-
35.5	47.6	3/4"	22.2	M10 x 23	12.5	61.7	171	87	87	51	1/2"	M8 x 20	40.5	18.2	-
B1		B2		B3		B4		B5		B6					
8		25 x 5		80 h9		89.5		8.6		36.2					
C1		C2		C3		C4		C5		C6		C7			
137		68.5		141		119		65		106		13			

C04 Type

A1	A2	A3	A4	A5	A6	A7	A8	A9	A10	A11	A12	A13	A14	A15	-
35.5	47.6	3/4"	22.2	M10 x 23	17	74.4	166.8	80	57	37	1/2"	M8 x 20	40.5	18.2	-
B1		B2		B3		B4		B5		B6					
8		25 x 5		80 h9		95.25		8.6		33.4					
C1		C2		C3		C4		C5		C6		C7			
137		25 x 5		137		119.4		65		113		13			

C07 Type

A1	A2	A3	A4	A5	A6	A7	A8	A9	A10	A11	A12	A13	A14	A15	-
35.56	47.625	3/4"	22.23	M10 x 23	17	74.43	166.8	80	57	37	1/2"	M8x20	39.98	18.24	-
B1		B2		B3		B4		B5		B6					
8		25 x 4.75		80 h9		95.25		8.64		33.4					
C1		C2		C3		C4		C5		C6		C7			
137		68.5		137		119.4		65		113		17.452			

C20 Type

A1	A2	A3	A4	A5	A6	A7	A8	A9	A10	A11	A12	A13	A14	A15	-
36	69.85	1.5"	35.71	M12x27	30.9	100	222	107	87	49.75	1"	M12x27	57.15	27.76	-
B1		B2		B3		B4		B5		B6					
8		31.75 x 8.00		110 h9		110		10.5		50.2					
C1		C2		C3		C4		C5		C6		C7			
173		87		173		155		94		124		25.00			

C38 Type

A1	A2	A3	A4	A5	A6	A7	A8	A9	A10	A11	A12	A13	A14	A15	-
37.5	69.85	1.5"	35.7	M12 x 24	34	117	282.7	125	125	59	1"	M12x27	57.15	27.76	-
B1		B2		B3		B4		B5		B6					
9		32 x 8		125 h9		150		14		42.2					
C1		C2		C3		C4		C5		C6		C7			
223		111		223		200		94		150		25.00			

Pump application

Operating pressures - general

The pump design features hydrostatic bearing faces for optimum efficiency and long life. The hydrostatic balance required for these bearings means that inlet pressure must never exceed outlet pressure, even when the pump is not rotating. This is normally simple to achieve on tank pressured systems. For systems using boost pump this may be possible by using a relief valve or by placing a check valve in parallel with the pump. This is to allow a possible flow from inlet to outlet so that pressures can be balanced from inlet to outlet during start up of the pump (this valve should close as soon as outlet pressure exceeds inlet pressure).

Warning:

Outlet pressure from the pump must always exceed inlet pressure to the pump. Failure to comply with this instruction may lead to damage or complete failure of the pump.

Important information - please read carefully

Outlet pressure

If the fluid contains certain fillers, blowing agents or other additives, maximum outlet pressure may have to be limited in order to achieve reliable running and reasonable life. For applications on fluids which include the above, or other additives please consult ROTARY POWER for further advice.

Maximum pump outlet pressures should not exceed the following in any circumstances

TDI fluid 210 Bar

MDI, Polyol fluid 250 Bar

Minimum outlet pressure 2 Bar or a value equal to or higher than inlet pressure, whichever is greater.

Inlet pressure

To achieve the correct inlet pressure conditions, the following must be considered at the inlet port of the pump.

1. Inlet pressure must not exceed outlet pressure.
2. Inlet pressure must be high enough to keep the fluid stable in all conditions, consistent with the fluid manufacturers recommendations.
3. Inlet pressure must be high enough with more viscous fluids, to eliminate cavitation within the pump.
4. Shaft seal life is dependant upon the case pressure (also pump speed and fluid cleanliness). The lower the inlet pressure, the longer the seal life.

Therefore the correct procedure for specifying the required pressure at the inlet port of the pump is:

- A. Check requirements for the specified fluid with the fluid supplier/manufacturer.
- B. Check with the chart 1 for the minimum inlet pressure at the inlet port for the specified fluid viscosity.

Shaft seal

Shaft seal life is dependant upon many factors, some examples are :

1. Shaft speed
2. Fluid lubricity
3. Fluid pressure
4. Fluid contaminant level
5. Nature and size of fillers used.

See seal selector chart, seal options are specified using the code on page 15 and graph 2 on page 5.

Pump application

Rotary Power offers two specifications for each model. The standard model offers serviceability, but for fluids with viscosity below 20 cSt Rotary Power recommends a special matched option.

The performance charts located on pages 4 and 5 refer to a standard model. The performance can be improved with special matching on the Rotor and Pistons.

Consult Rotary Power for details.

Pipework sizing

Pipework sizing should be calculated taking into consideration whether it is for pump inlet or delivery, and pressure drop through the line.

Noise

Noise will vary with respect to displacement and speed. For typical noise performance refer to graph below.

Output flow

Pumps fitted with variable displacement control should not be operated at less than 10% of full displacement. For further advice consult ROTARY POWER.

Pump materials

C range pumps are built using a combination of high grade steels and S.G. Iron. All major components are treated for internal corrosion resistance by various heat treatment processes. Shaft Seals are a combination of viton and PTFE running on a ceramic bush.

Noise @ maximum displacement, 1500 rpm measured 1 m from rear of pump. Fluid viscosity 20cSt, fluid density 880³ Kg/m (includes background noise 56 dBa)

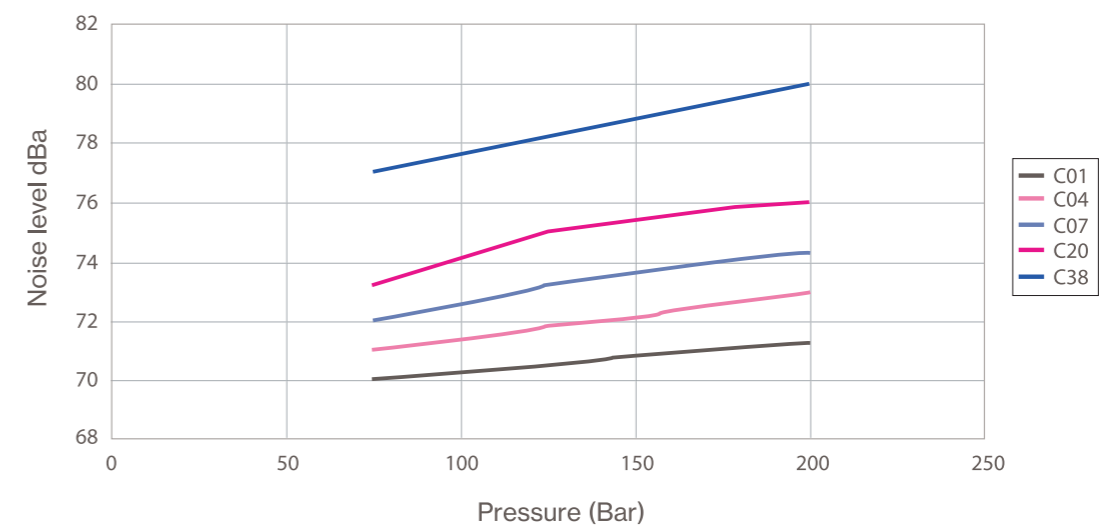

Commissioning & installation

Commissioning

Pump shaft rotation must be in compliance with the pump body indicators i.e. CW means clockwise shaft rotation whilst looking from the shaft end of the pump.

Inlet and outlet pipework must be checked for connection to the correct pump ports. A case drain pipe is not required.

There are five bleed points located in the pump body. Depending upon the orientation of the pump, one or more of these bleed points must be used to ensure that the pump case is completely filled, prior to start up.

Care should also be taken to purge all air from the inlet, AND outlet pipe-work, prior to start up. During this operation the pump shaft should be rotated slowly to fill the rotating group.

The space which exists between the inner and outer shaft seals must, at all times be filled with a suitable, "Barrier" fluid i.e. Mesamol. Access to this space is provided by two 1/8 inch BSP ports located at either side of the mounting flange. Care must be taken to completely purge this space of all air, to allow lubrication of outer shaft seal. The supply of barrier fluid can be maintained using small transparent reservoirs, connected to access ports.

Inner seal leakage can be detected by regular inspection of the barrier fluid in the reservoirs.

Barrier fluids containing water or, that are hygroscopic or, are in any way incompatible with the pumped fluid must not be used.

Pressurisation of the barrier fluid may cause shaft seal failure. Therefore pressurised fluid or grease systems, such as a sprung dashpot and tap arrangement must not be used.

Pumps fitted with manual adjustment i.e. types MD, MB, ME have a leakage indicator port to provide access to the space between the inner and outer seals of the swash adjusting shaft. This space should be provided with the same barrier fluid reservoir systems as described in the above.

Initial start up of the pump should always take place with minimum permitted outlet pressure, running for a period of time on recirculation at full flow, to purge any air that may still be in the system.

Check and set system relief valves.

Check pump inlet and outlet pressure at the pump whilst stationary and running in all conditions. Ensure the relationship between pressures recorded is within the system design parameters and also complies with pump requirements given in this brochure.

Take fluid samples and check for cleanliness.

Measure flows within required working range and ensure, stable delivery is achieved.

Check temperatures of fluid at pump outlet and pump main case and compare with fluid temperature at pump inlet. Any significant difference (over 15 - 20°C) should be investigated.

After the first few hours operation, clean or renew (as appropriate) all filters.

Operation

Recommended inlet pressure should always be maintained at the inlet port at start up and during running. Pumps fitted with manual variable displacement controls should not be adjusted when the pressure, at either port, is greater than 100 bar.

Adjustment of a manual control should always be completed by turning the control in a clockwise direction.

Example :

1. To increase flow. Release lock nut, turn control clockwise and lock in position.
2. To decrease flow. Release lock nut, turn control anti clockwise until two turns below required flow, then turn clockwise to required setting and lock in position.

Ensure that the system is always full of fluid otherwise immediate pump damage will occur. Barrier fluid levels should be maintained and checked for contamination regularly.

Maintenance

C range pumps are self lubricating and preventative maintenance is limited to keeping system filters clean. Keep barrier lubrication systems topped up and inspected for contamination, keep all fittings and screws tight and inspect for leaks. Periodically inspect drive coupling for wear.

Service

Shaft seals will wear and need periodic replacement. Seal kits are available for on site renewal and it is recommended that on site stocks are held for immediate use.

Note:

Units returned for factory overhaul must be flushed clean and all hazardous fluids must be neutralised before despatch to Rotary Power

General

- Protective plugs and covers should remain in position until the pump is installed.
- Ensure the system is clean prior to pump installation.

Drive shaft coupling

Rotary Power recommend a flexible drive coupling which allows for axial and radial misalignment. It is important that the drive coupling does not impose an axial or radial load into the drive shaft.

Warning:

Failure to comply with this instruction will result in erratic performance and pump failure.

Mounting

A location spigot and slotted fair bolt flange are provided for mounting to ensure the unit fits correctly the bore of recipient housing should have a 1mm lead in chamfer and have flat machined face. Recommend a bore size clear of the spigot by 0.025 to 0.075mm

Accessories & ordering code

Magnetic drive couplings

Magnetic drives can be installed to give high reliability with zero leakage. May require cooling flow through magnetic areas due to generated heat from the magnets and shear of high viscosity fluids. Available upon request and consultation.

Relief valves

Pressure port mounted system relief valves can be supplied by Rotary Power. Sandwiched between the pressure port and outlet flange they provide a safety pressure override and can be fed directly back to inlet or vented to air as required. Available upon request and consultation.

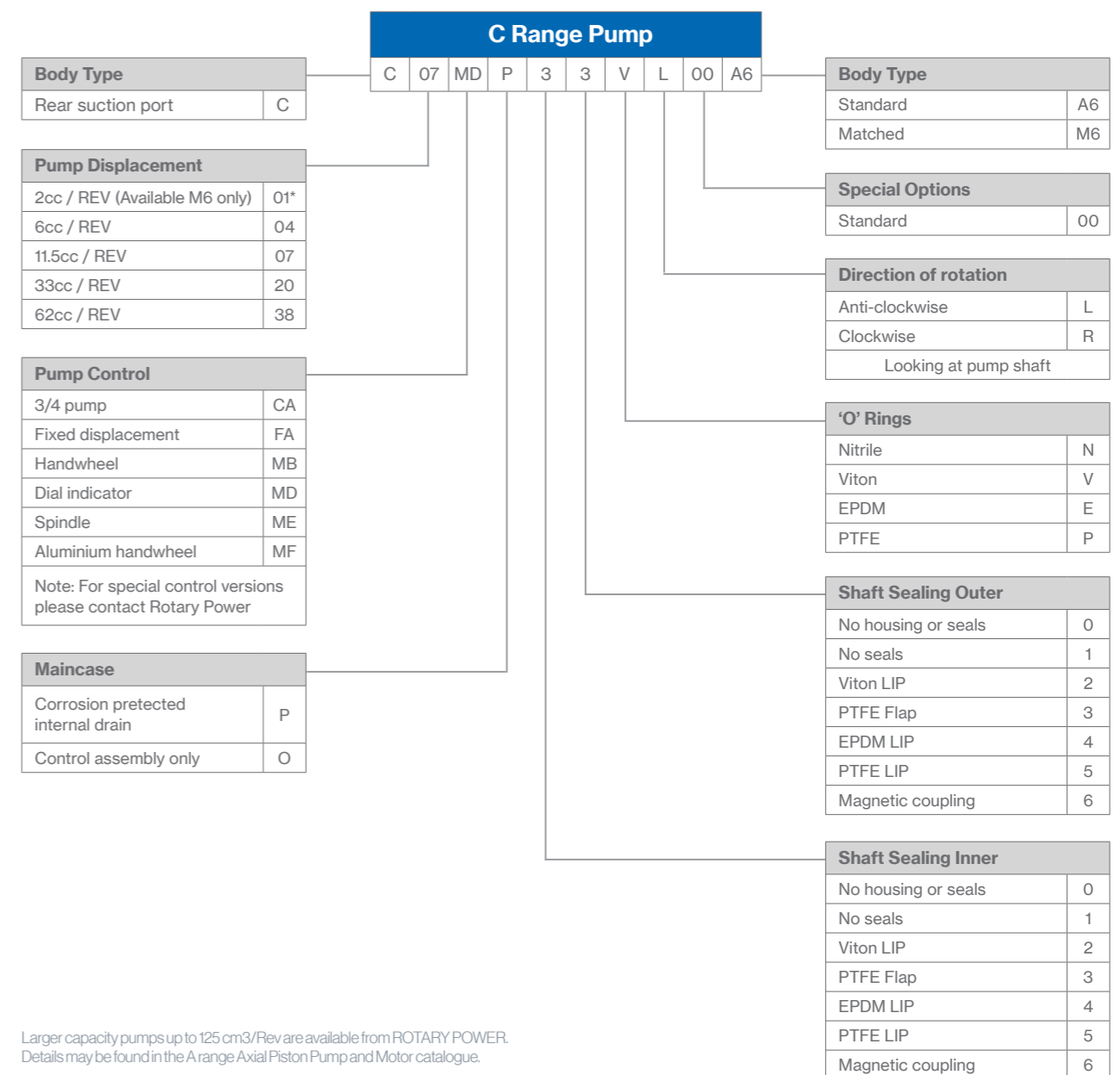

Larger capacity pumps up to 125 cm³/Rev are available from ROTARY POWER. Details may be found in the A range Axial Piston Pump and Motor catalogue.

UK

ROTARY POWER LTD
Waldrige Way
Simonside East Industrial Park
South Shields
NE34 9PZ
Tel: +44 (0) 191 276 4444
Fax: +44 (0) 191 276 4462
Email: enquiries@rotarypower.com
www.rotarypower.com

USA

ROTARY POWER INC
6009 West 41st Street
Suite 2, Sioux Falls
SD 57106
Tel: +1 (605) 361 5155
Fax: +1 (605) 362 1949
Email: info@rotarypower.com
www.rotarypower.com

GERMANY

ROTARY POWER
Vertriebsgesellschaft mbH
Nordstrasse 78
52078 Aachen-Brand
Germany
Tel: +49 (0) 241 955190
Fax: +49 (0) 241 9551919
Email: info.ac@rotarypower.com
www.rotarypower.com

INDIA

ROTARY POWER DIVISION
British Engines (India) Pvt Ltd
6A, Attibele Industrial Area
Hosur Road
Anekal Taluk
Bangalore – 562 107
Tel: (80) 782 0011
Fax: (80) 782 0013
Email: indiaenquiries@rotarypower.com
www.rotarypower.com



You are at the **centre**
of everything we do