



 **HYDRO
LEDUC**
make it simple

Contents



■ Definition and main applications	1
■ Determining power and torque	1
■ Fixed displacement micropumps:	
■ PB32 - 32.5 - 33 - 33.5 - 33 HP	2
■ PB36.5	4
■ PF 56.5	6
■ PB1.1 / PB1.2 / PB1.75	8
■ Variable displacement micropumps:	
■ PBV 56.5 / 57.5	10
■ PVE 56.5 / 76.5	10
■ Hydraulic micromotors	13
■ Accessories	15
■ Complete functions	18
■ Installation and start-up	29
■ The complete LEDUC product range	21

Microhydraulics makes it feasible to obtain several tons of force from a minimal power source within a very restricted space envelope.

The techniques of microhydraulics allow simple easy-to-use solutions to problems that are often at or beyond the limits of traditional mechanical options.

HYDRO LEDUC offers a complete range of micropumps, hydraulic micromotors and valves, which all have proven capability of operation in extreme conditions of temperature and environment.

Based on a "standard" range, customized models can also be offered, with a choice of:

- drive shafts;
- inlet and outlet ports;
- flanges or threaded connections.

Furthermore, for your specific projects, HYDRO LEDUC offers complete integrated pump-motor units, and complete power packs, designed and built to meet your specifications.

Let us surprise you with the innovative solutions possible from HYDRO LEDUC!

Contact us for your next requirements!



**HYDRO
LEDUC**

HYDRO LEDUC
Head & factory
BP 9
F-54122 AZERAILLES
(FRANCE)
Tél. +33 (0)3 83 76 77 40
Fax +33 (0)3 83 75 21 58

Definition and main applications

LEDUC micro-hydraulics offers a complete and original design wherever considerable force is required within a small space envelope with very limited output power available.

Examples of particularly demanding applications already mastered include:

- providing 13 tons of crimping force for a handtool barely larger than a cordless drill;
- ensuring the operational reliability of oil tools for exploration and measurement while drilling, where the entire hydraulics envelope may fit into a housing of no more than 1.18 to 1.57 in (30 to 40 mm) in diameter;
- allowing oceanographic research drifters, deployed throughout the world's oceans, to resurface regularly, and above all with total reliability;
- guaranteeing the efficiency of guidance systems installed on the most modern fighter aircraft.

The wide range of high technology industries concerned all require extensive know-how, and each new application tends to push through the limits of previous technology.



How to determine your LEDUC pump

1. Conversion table imperial/metric

Value	SI unit	Imperial unit	Conversion
Displacement / Volume	mm ³	Cu.in (in ³)	1 cu.in = 16 387 mm ³
Torque	N.m	Lbs.ft	1 lbs.ft = 1.356 N.m
Length	mm	In	1 in = 25.4 mm
Pressure	bar	PSI	1 bar = 14.5 PSI
Power	W	HP (horsepower)	1 HP = 746 W
Flow	cm ³ /min	USgal/min (ou GPM)	1 USgal/min = 3785 cm ³ /min
Weight	kg	Lbs (pound)	1 kg = 2.2 lbs

2. Determining the pump displacement required

2.1. If we know the flow Q and motor speed N, we can calculate the required pump displacement cyl:

$$cyl = \frac{Q}{N} \times 1000$$

$$cyl = \frac{Q}{N} \times 231$$

2.2. Choose the closest displacement pump in our catalogue, then adapt flow or rotating speed depending on the application:

$$Q = \frac{cyl \times N}{1000}$$

$$Q = \frac{cyl \times N}{231}$$

or

$$N = \frac{Q \times 1000}{cyl}$$

or

$$N = \frac{Q \times 231}{cyl}$$

For your most demanding applications, HYDRO LEDUC can make the exact displacement to suit the application. Please contact us.

3. Calculating actual flow

All hydraulic pumps have an internal leakage which is proportional to working pressure. This leakage volume is quantified by the volumetric efficiency μ_{vol} . Actual flow is calculated with the following formula:

$$Q_{real} = Q \times \frac{\mu_{vol}}{100}$$

$$Q_{real} = Q \times \frac{\mu_{vol}}{100}$$

Volumetric efficiency μ_{vol} as a function of working pressure is given for each fixed displacement pump. The values shown are for standard usage (room temperature and mineral-based hydraulic fluid), and will vary by application

4. Calculating torque calculation

The torque C_{th} absorbed by the pump is calculated from its displacement cyl and pressure P

$$C_{th} = \frac{1.59 \times cyl \times P}{100\ 000}$$

$$C_{th} = \frac{cyl \times P}{75.4}$$

Increase torque C_{th} by estimated mechanical efficiency μ_{meca} . to get actual drive torque C_u :

$$C_u = C_{th} \times \frac{100}{\mu_{meca}}$$

$$C_u = C_{th} \times \frac{100}{\mu_{meca}}$$

Initially, use 80% as estimate of mechanical efficiency.

5. Calculating power on motor shaft

Motor power W is calculated using torque C_u and rotating speed N.

$$W = \frac{C_u \times N}{9.55}$$

$$W = \frac{C_u \times N}{5254}$$

6. Quick calculation formula

An approximate value for power absorbed by the pump can be calculated using the following formula:

$$W = \frac{cyl \times P \times N}{480\ 000}$$

$$W = \frac{cyl \times P \times N}{317\ 000}$$

Calculations in METRIC units are shown in blue and calculations in IMPERIAL units are shown in green

Fixed displacement micropumps

PB32 -PB32.5 -PB33 -PB33.5 -PB33HP

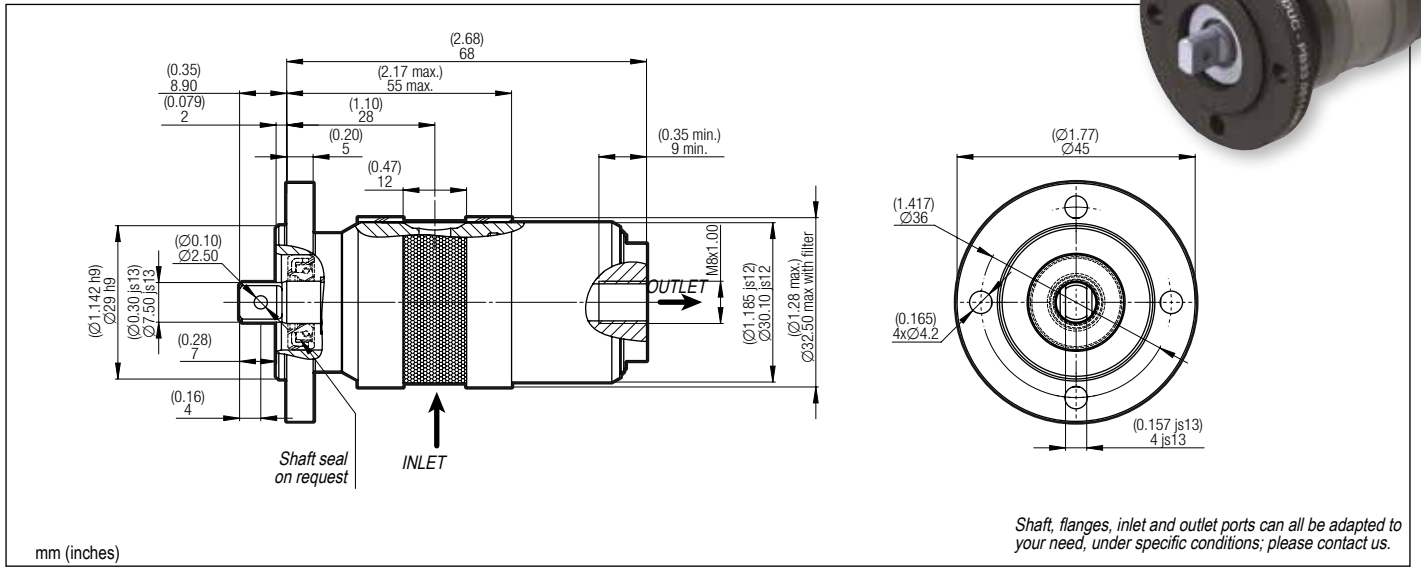

Characteristics

Type of pump		Displacement		Direction of rotation	Max. rotating speed (rpm)		Max. pressure			
		mm ³	Cu.in		continuous	peak	continuous		peak	
							bar	PSI	bar	PSI
PB32	0518110	12	0.0007	CW & CCW	5000	6000	300	4350	350	5075
	0523370	20	0.0012		5000	6000	300	4350	350	5075
	0523380	25	0.0015		5000	6000	300	4350	350	5075
PB32.5	0511860	45	0.0027		5000	6000	300	4350	350	5075
PB33	053220	45	0.0027	CCW	5000	6000	300	4350	350	5075
PB33.5	057000	70	0.0042	CCW	5000	6000	300	4350	350	5075
PB33 HP	054560	45	0.0027	CW	5000	6000	900	13050	1000	14500

Up to 1000 bar peak

Technical characteristics

- Max. operating temperature: 200°C (392°F)
- Weight (standard pump): 0.33 kg (0.66 lbs)

Absorbed torque as a function of pump outlet pressure

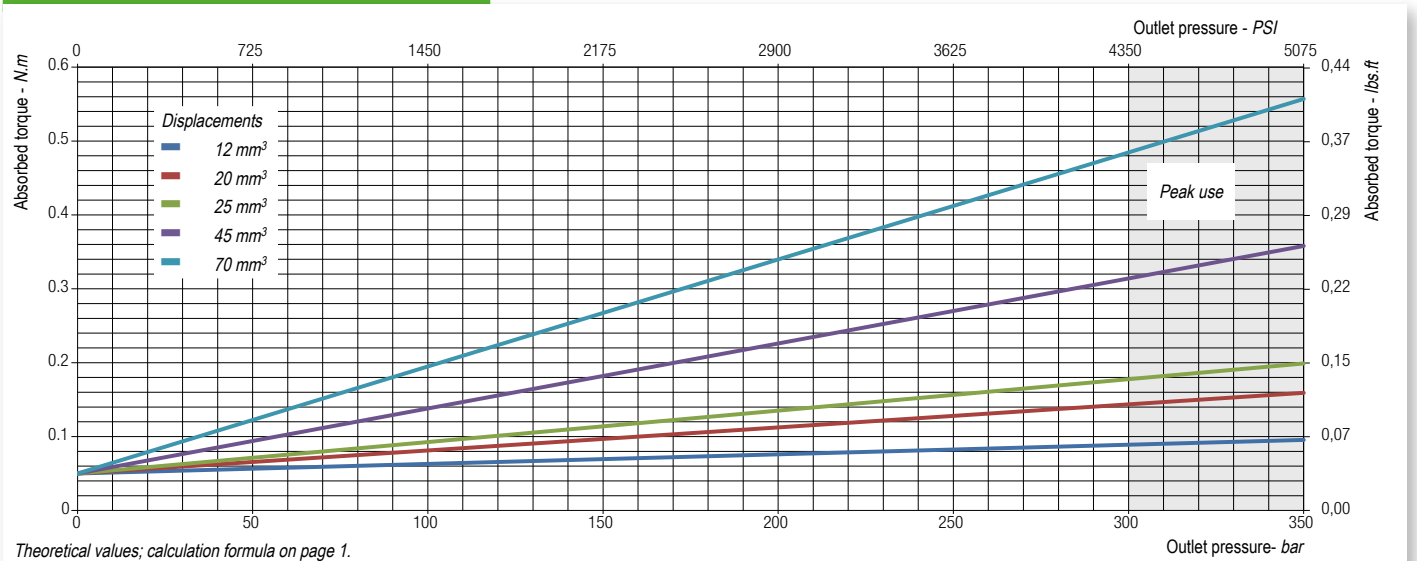

Fixed displacement micropumps

PB32 -PB32.5 -PB33 -PB33.5 -PB33HP

Flow as a function of rotating speed

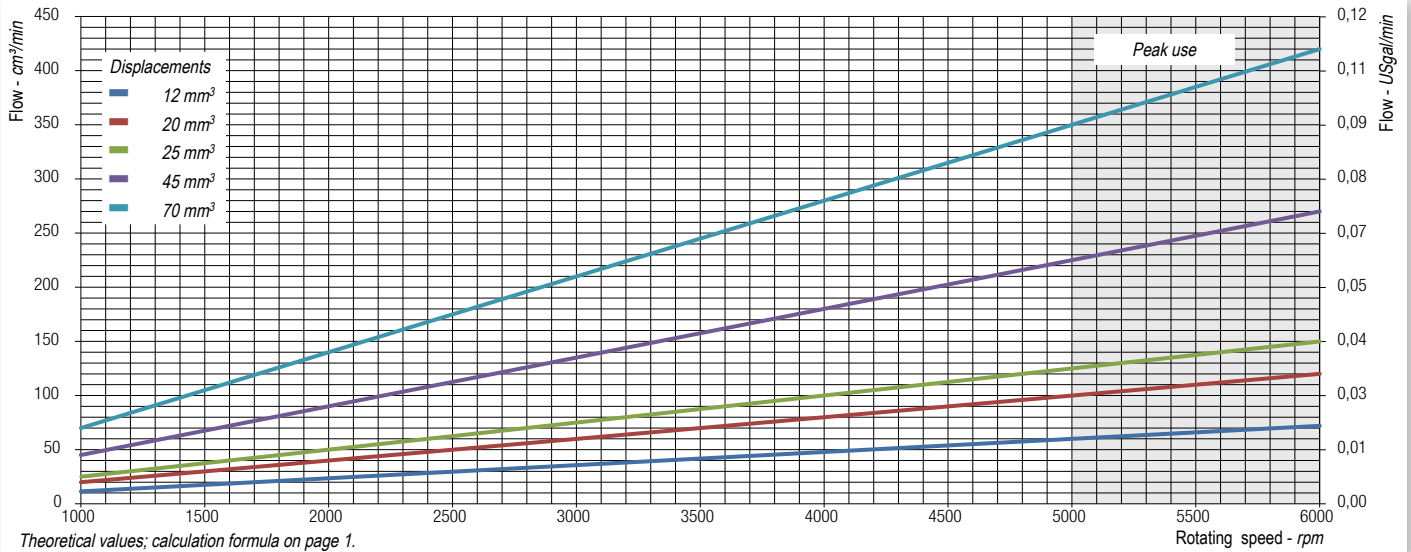

Volumetric efficiency as a function of outlet pressure

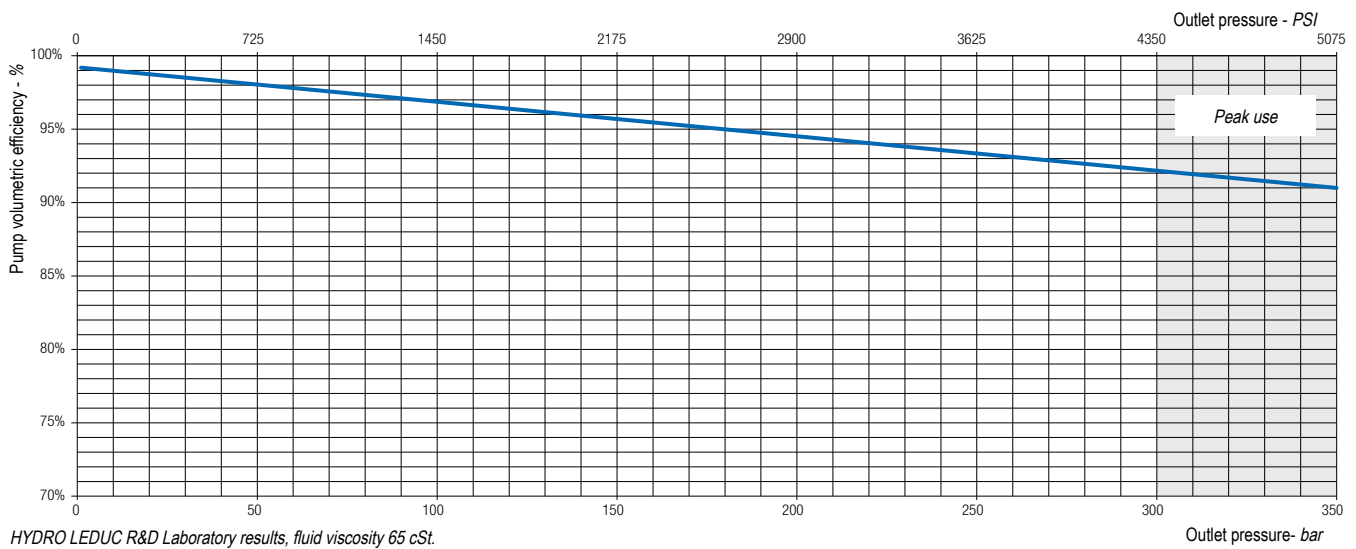

Absorbed torque as a function of outlet pressure – PB33HP

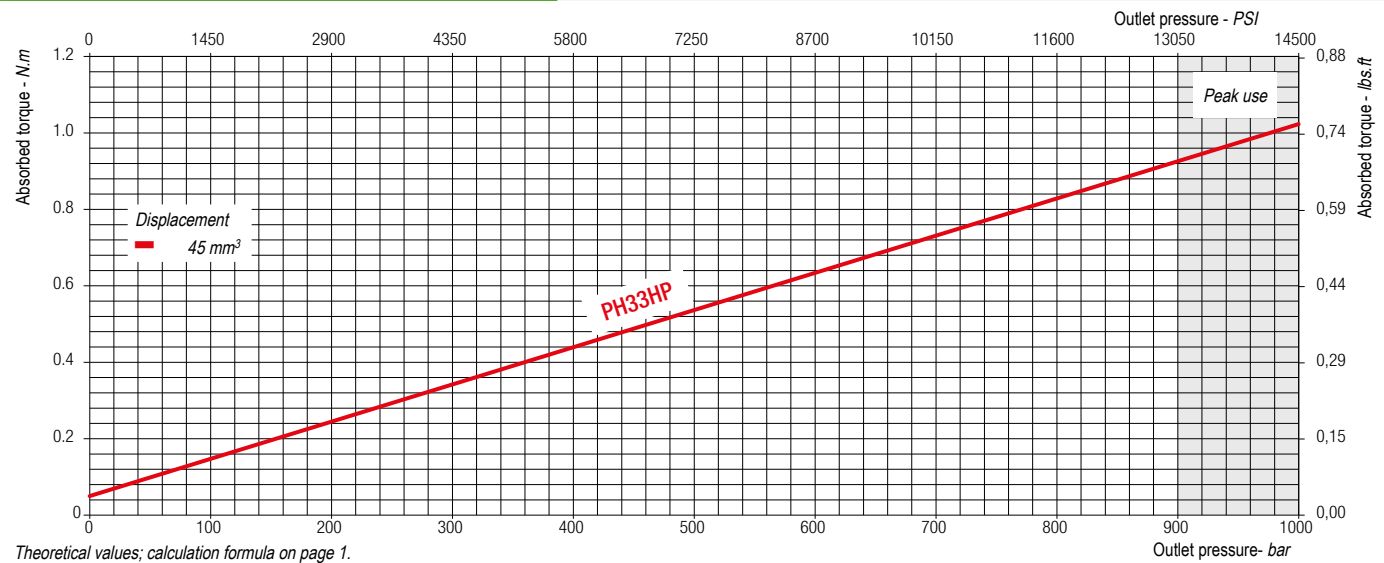

Fixed displacement micropumps PB36.5

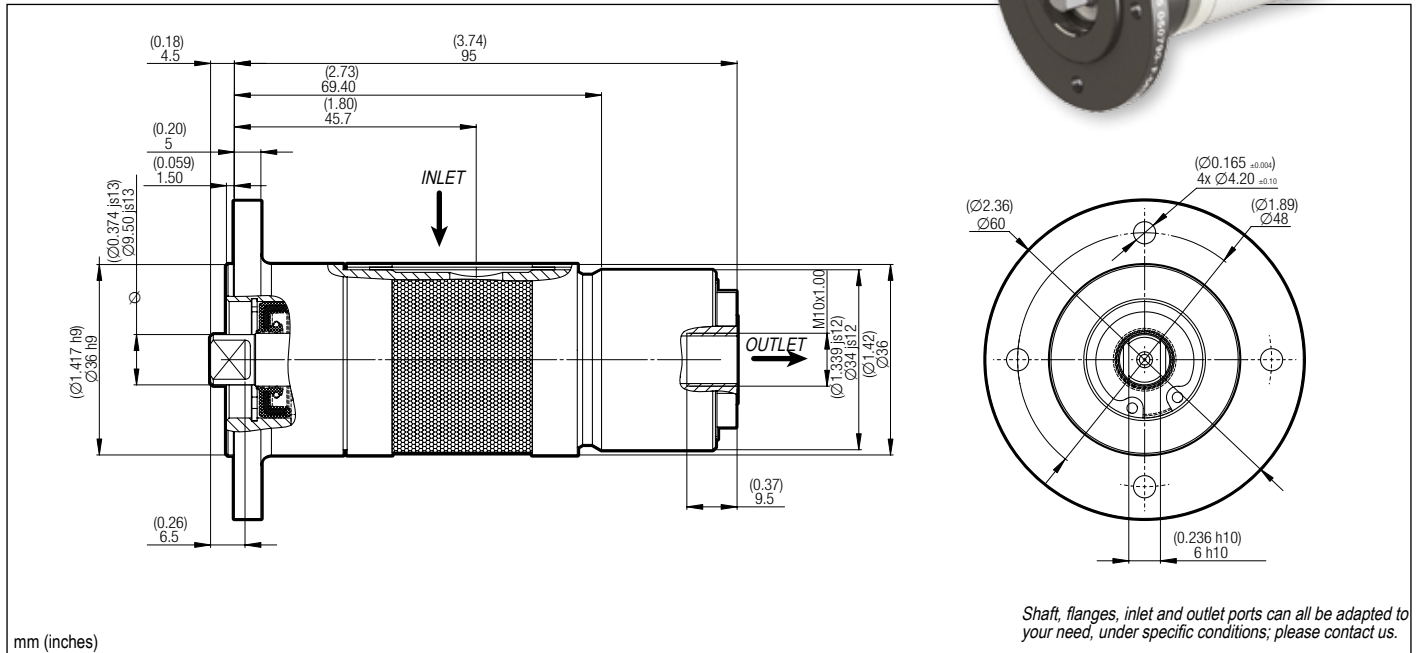
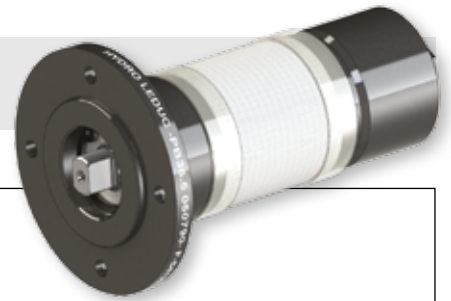

Characteristics

Type of pump	Displacement	Direction of rotation	Max. rotating speed (rpm)		Max. pressure					
			mm ³	Cu.in	continuous	peak	continuous	peak		
			bar	PSI	bar	PSI	bar	PSI		
PB36.5	050720	115	0.0070	CCW	5000	6000	300	4350	350	5075
	050790	280	0.0170	CW	5000	6000	300	4350	350	5075
	057310	360	0.0220	CCW	5000	6000	300	4350	350	5075

Technical characteristics

- Max. operating temperature: 200°C (392°F)
- Weight (standard pump): 0.6 kg (1.32 lbs)

Fixed displacement micropumps PB36.5

Absorbed torque as a function of outlet pressure

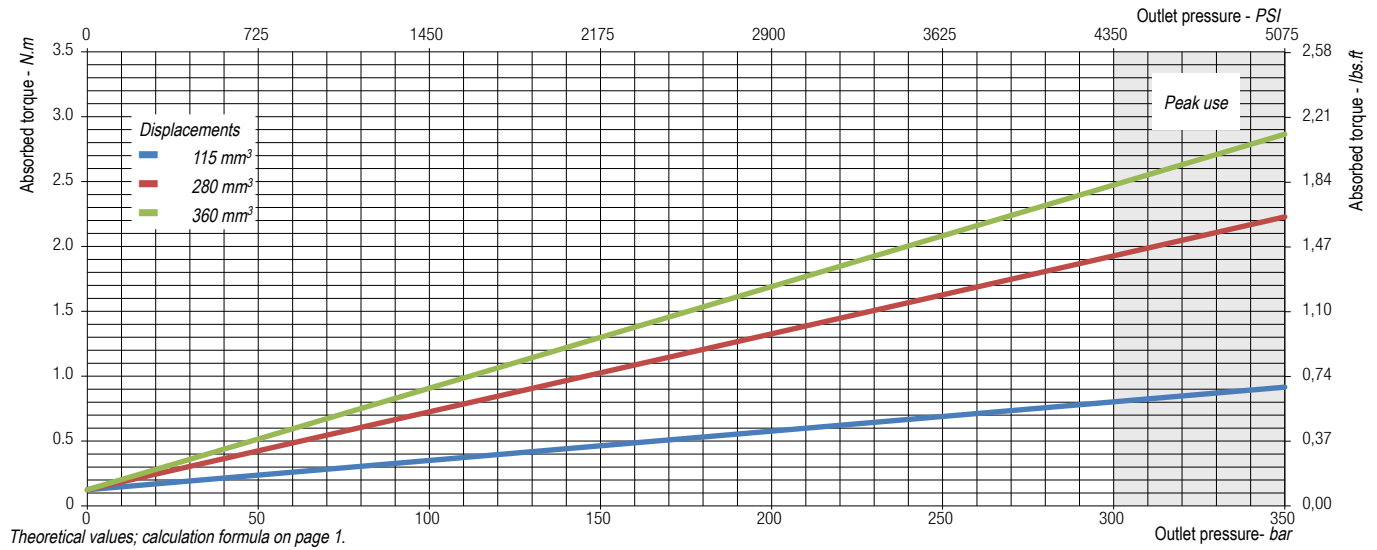

Flow as a function of rotating speed

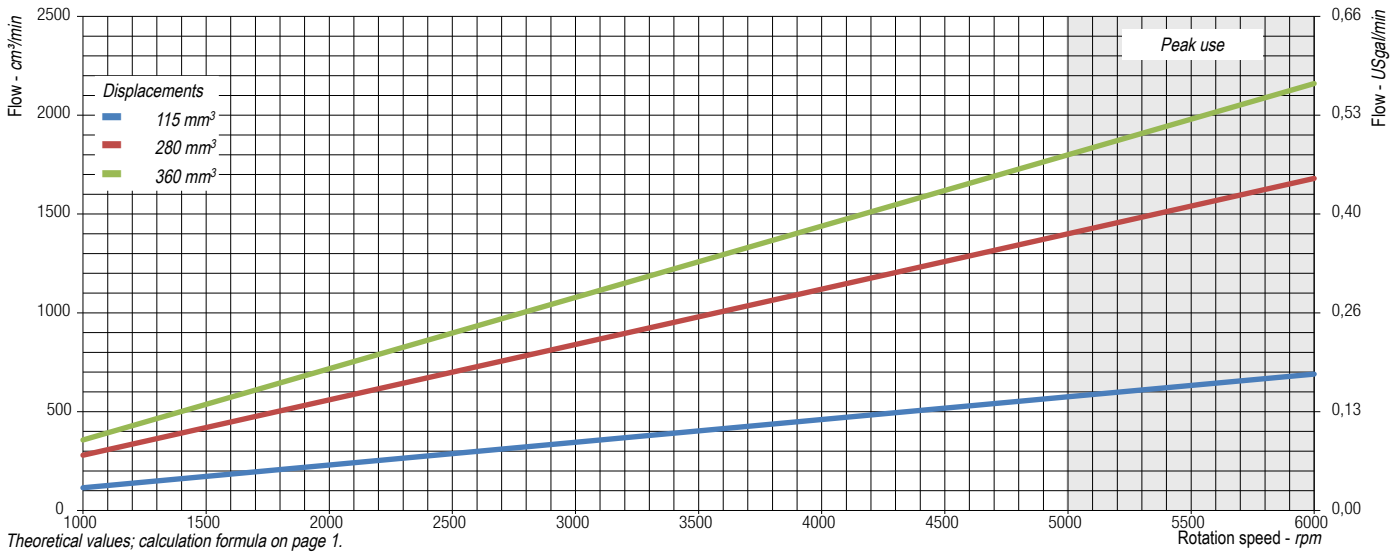

Volumetric efficiency as a function of outlet pressure

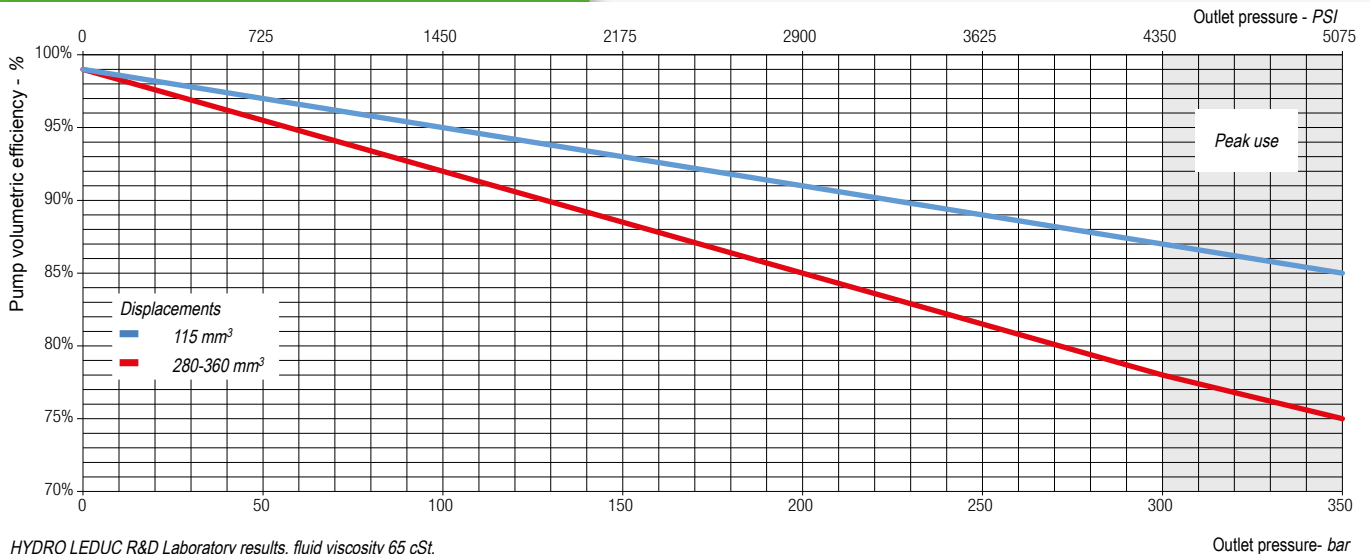

Fixed displacement micropumps PF56.5

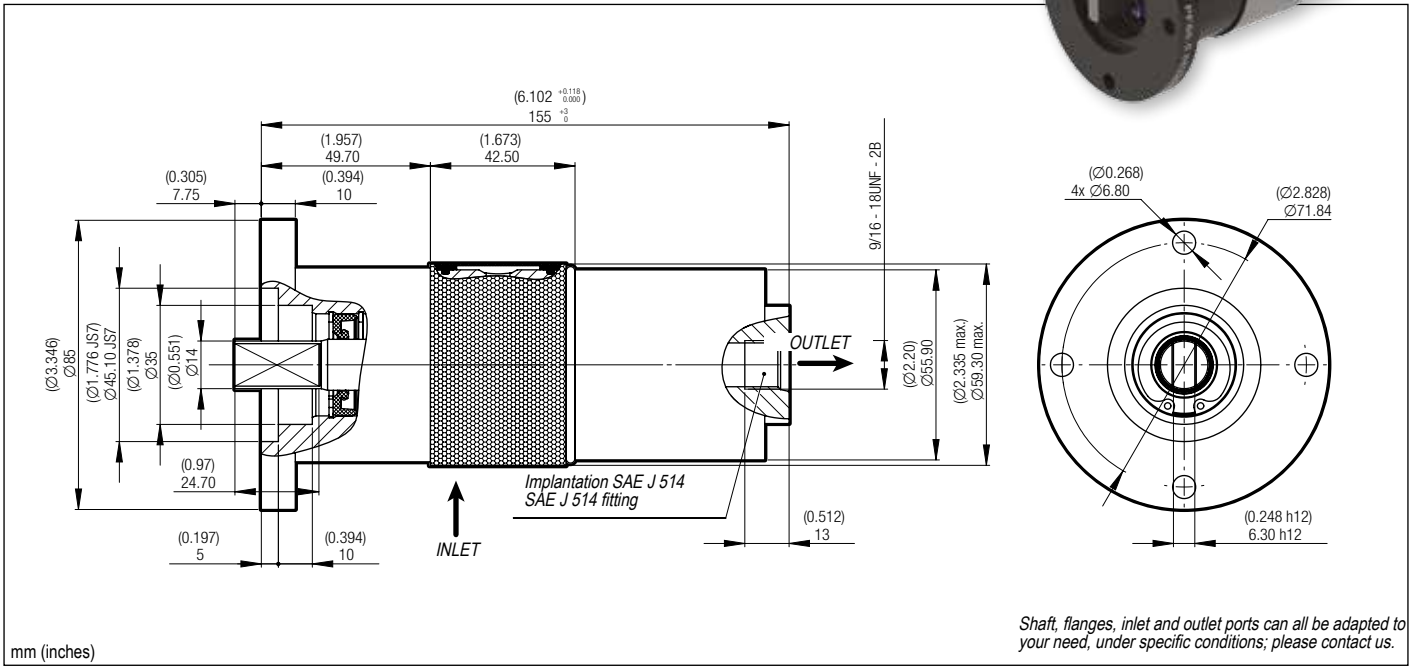

Characteristics

6

Type of pump	Displacement	Direction of rotation	Max. rotating speed continuous	Max. pressure					
				continuous	peak	continuous	peak		
	mm ³	Cu.in	rpm	bar	PSI	bar	PSI		
PF56.5	0523400	750	0.0458	CW	4000	300	4350	350	5075
	0515970	1000	0.0610	SH	4000	300	4350	350	5075

Technical characteristics

- Max. operating temperature: 200°C (392°F)
- Weight (standard pump): 2.5 kg (5.5 lbs)

Fixed displacement micropumps PF56.5

Absorbed torque as a function of outlet pressure

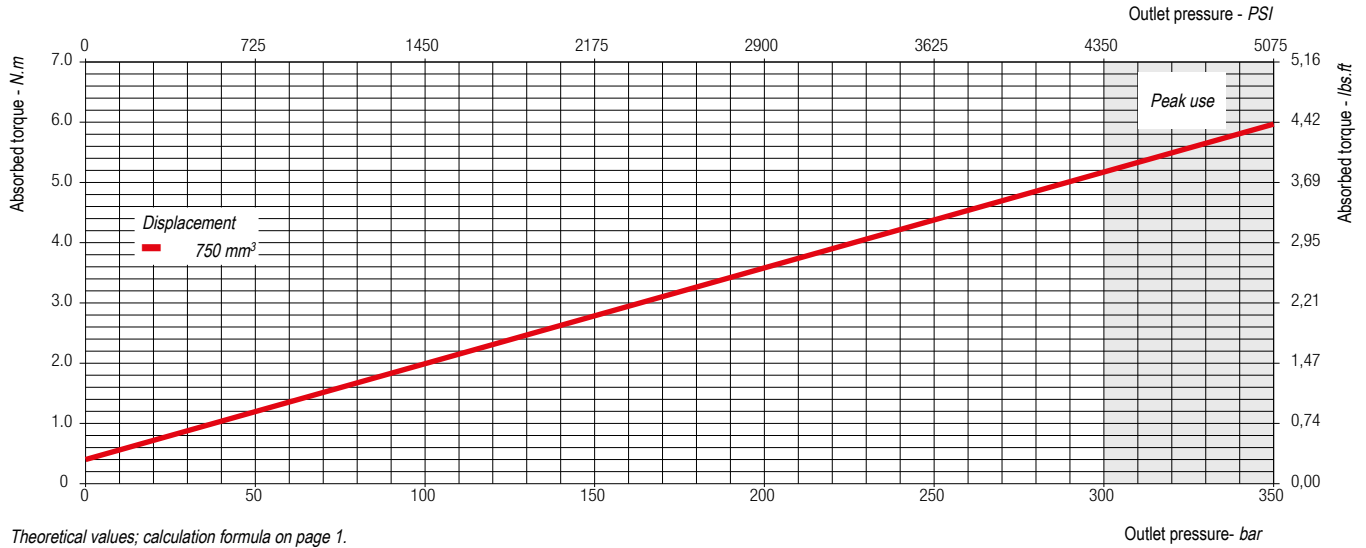

Flow as a function of rotating speed

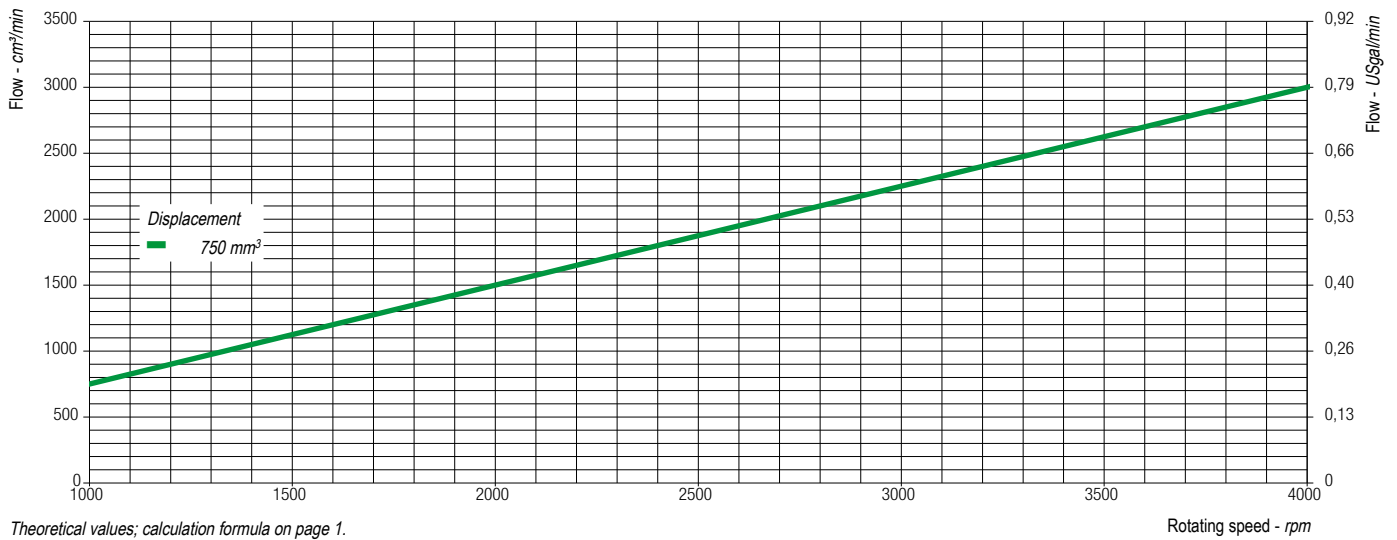

Volumetric efficiency as a function of outlet pressure

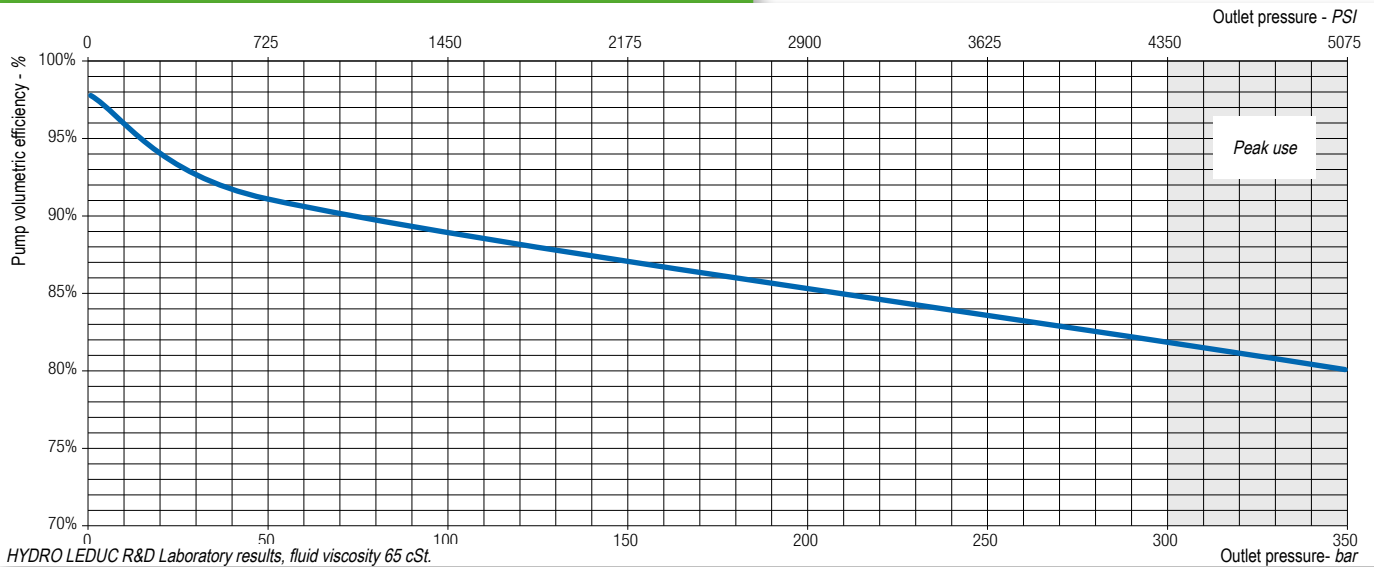

Fixed displacement micropumps

PB1.3 - PB1.75 - PB2.2

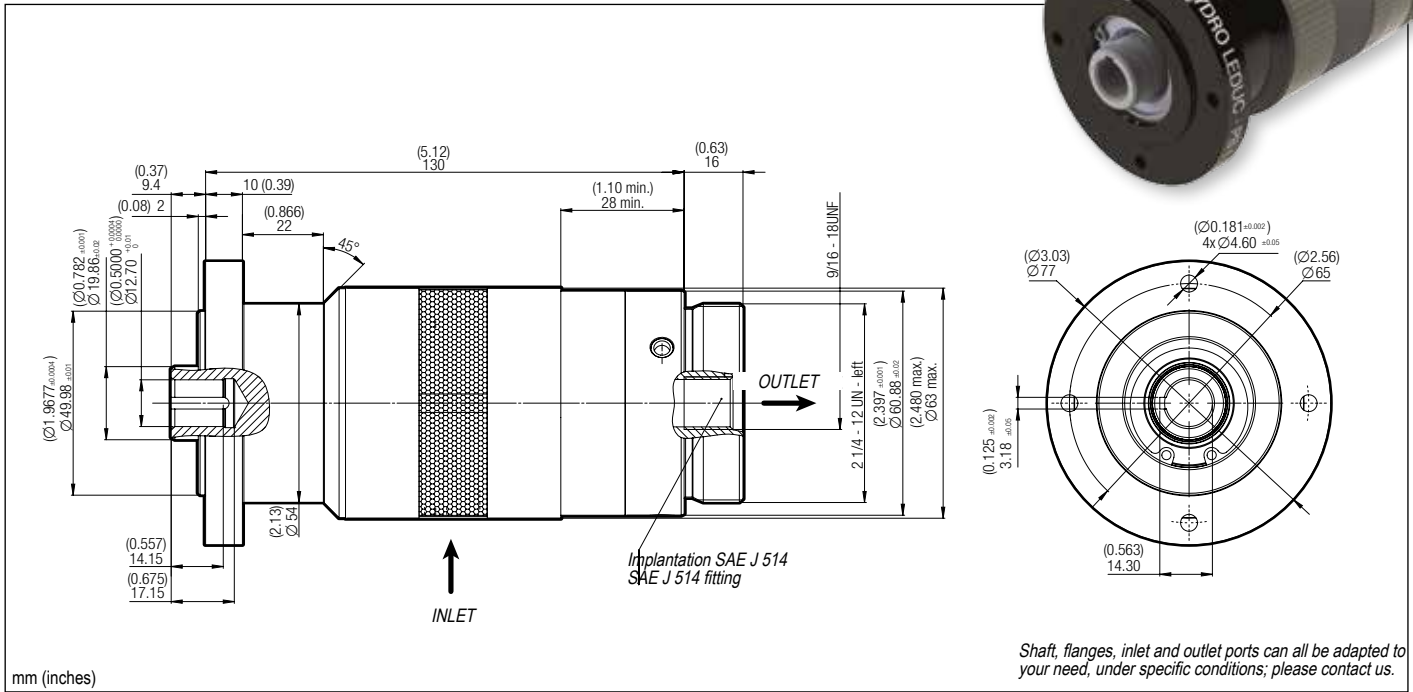

Characteristics

Type of pump	Displacement	Direction of rotation		Max. rotating speed continuous rpm	Max. pressure continuous		
		mm ³	Cu.in		bar	PSI	
PB1.3	0515640	1300	0.0793	CCW	4000	350	5075
PB1.75	0526410	1750	0.1068	CCW	4000	350	5075
PB2.2	0515160	2200	0.1343	CCW	4000	350	5075

Technical characteristics

- Max. operating temperature: 200°C (392°F)
- Weight (standard pump): 2.2 kg (4.8 lbs)

Fixed displacement micropumps PB1.3 - PB1.75 - PB2.2

Absorbed torque as a function of outlet pressure

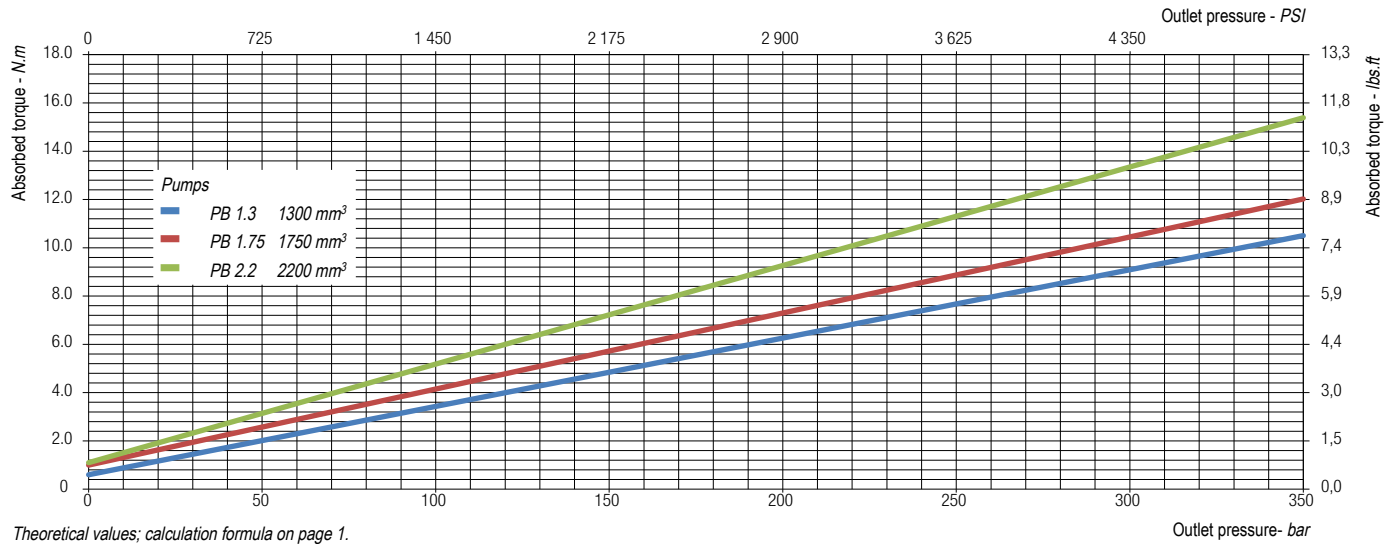

Flow as a function of rotating speed

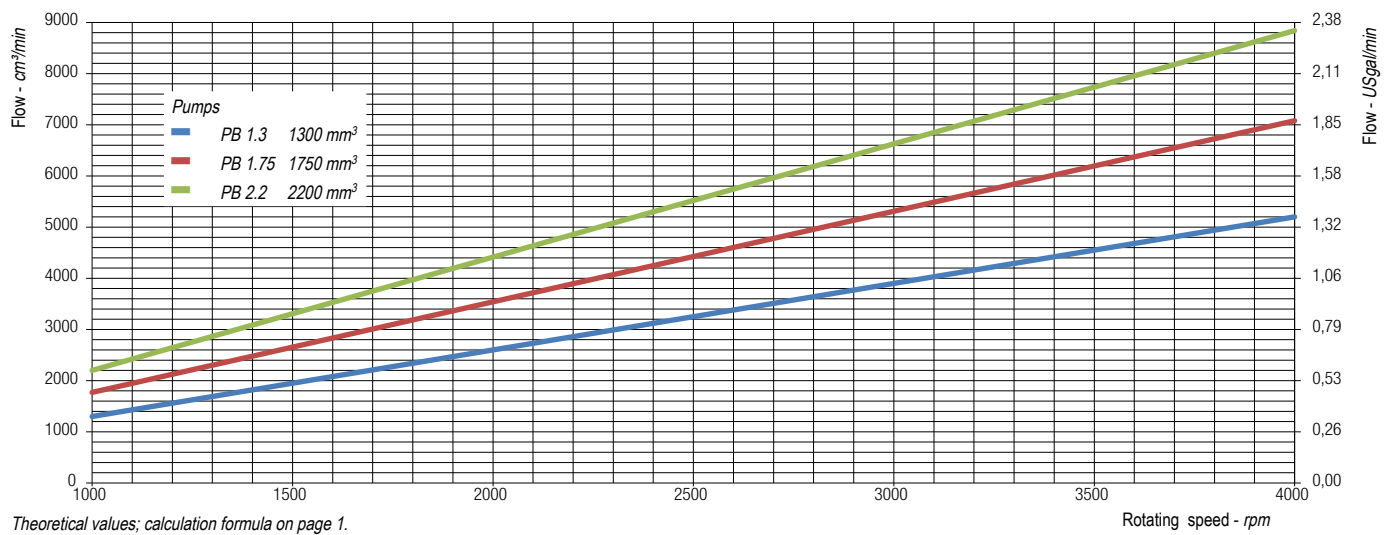

Volumetric efficiency as a function of outlet pressure

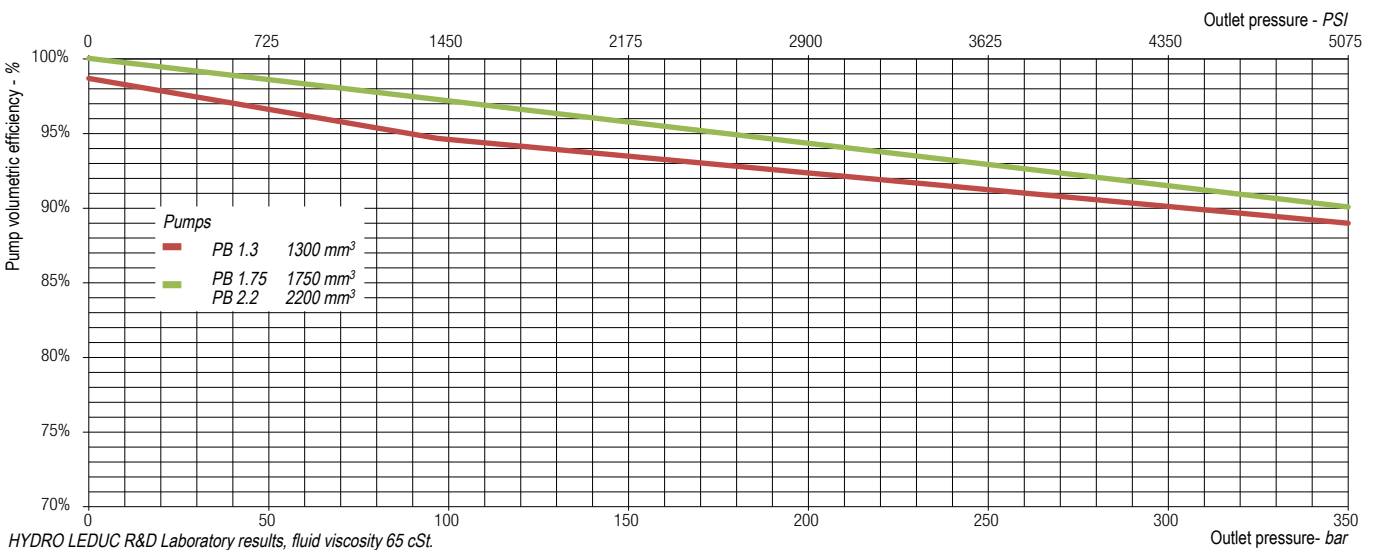

Variable displacement micropumps PBV56.5 - PBV57.5

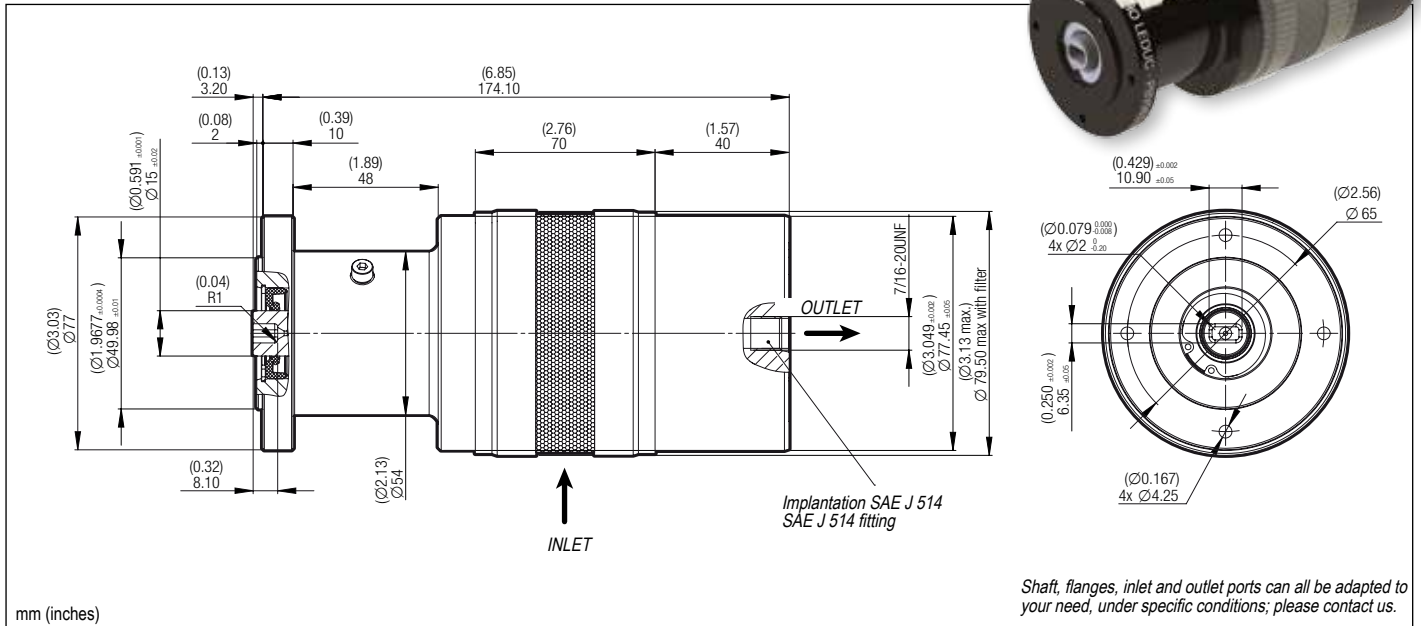

ADJUSTABLE PUMPS (with factory set adjustment)

The displacement of PBV pumps is adjustable as a function of outlet pressure, in order to limit power consumption. When outlet pressure is low, the pump operates at maximum flow. When outlet pressure increases, pump displacement and flow gradually decrease (see graphs on page 12).

10

Characteristics

Type of pump	Inlet	Direction of rotation	Rotating speed (rpm)		Displacement mini		Displacement maxi		Absorbed power at nominal speed with regulation		Max. pressure				
			nominal	permissible continuous operating	maxi	peak	mm ³	Cu.in	mm ³	Cu.in	W	HP	continuous	peak	continuous
												bar	PSI	bar	PSI
PBV56.5	0520570	Radial	CW	3150	3500	300	0.0183	1100	0.0671	550	0.737	250	3625	350	5075
	058120	Rear	CW	3150	3500	300	0.0183	1100	0.0671	550	0.737	250	3625	350	5075
PBV57.5	0511740	Radial	CW	3500	3500	540	0.0330	1500	0.0915	1100	1.475	250	3625	350	5075

The minimum displacement and the maximum power consumption are factory set (see graphs) and cannot be modified by the user. Other settings are possible; please contact us.

Technical characteristics

- Max. operating temperature: 200°C (392°F)
- Weight (standard pump) 4.2 kg (9.3 lbs)

Graphs (see page 12)

- Power consumption
- Flow as a function of outlet pressure

Also available with rear inlet

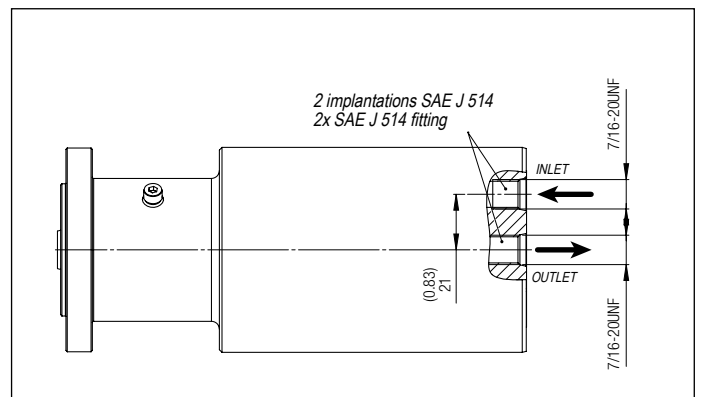

Variable displacement micropumps PVE56.5 - PVE76.5

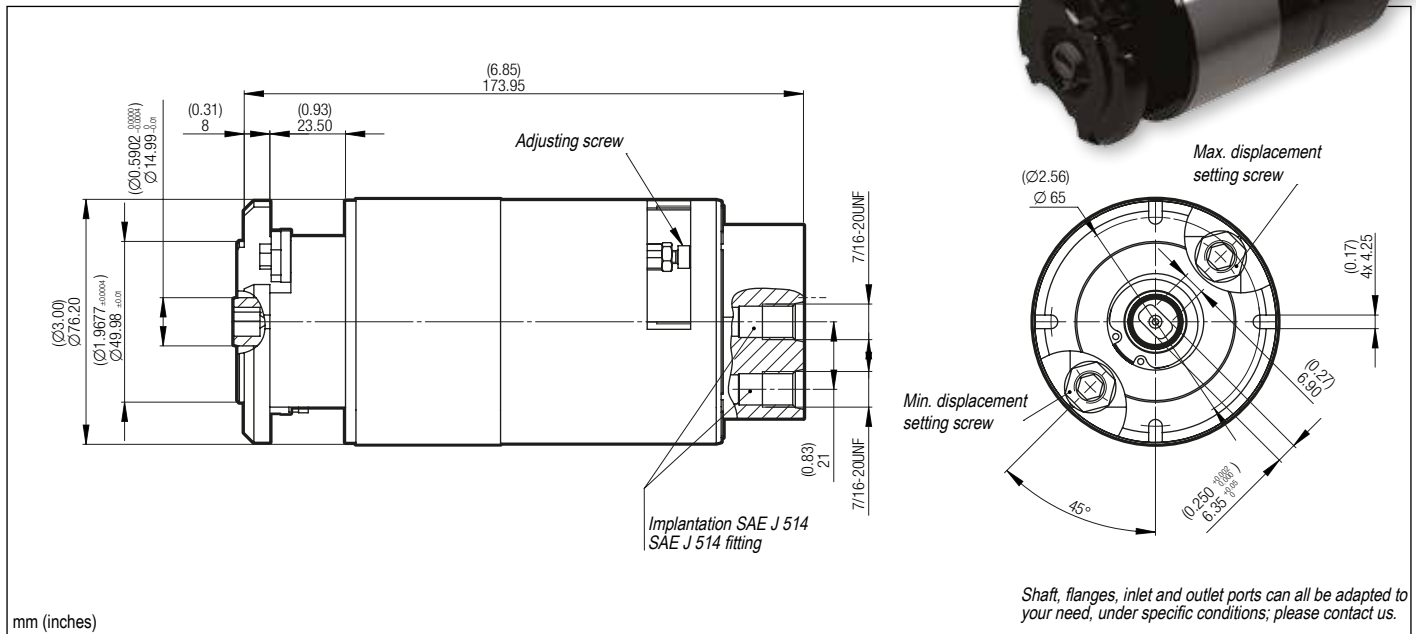

ADJUSTABLE PUMPS (with external adjustment screw)

PVE pumps offer the same possibilities as the PBV (adjustment of the displacement as a function of outlet pressure).

These pumps are fully adjustable by the user in terms of:

- max. displacement
- min. displacement
- pressure at which the flow regulation starts

Characteristics

Type of pump	Direction of rotation	Rotation speed (rpm)	Displacement setting				Max. pressure					
			nominal	maximal	MINI	MAXI	continuous	peak	bar	PSI		
PVE56.5	0520380	CW	3150	3500	mm ³ 0 to 750	Cu.in 0 to 0.0458	mm ³ 400 to 1150	Cu.in 0.0244 to 0.0702	bar 250	PSI 3625	bar 350	PSI 5075
PVE76.5	0522800	CW	3150	3500	mm ³ 0 to 1050	Cu.in 0 to 0.0641	mm ³ 560 to 1610	Cu.in 0.0342 to 0.0982	bar 250	PSI 3625	bar 350	PSI 5075

Maximum absorbed power corresponds to the standard factory setting (see graphs).

Other settings are available, please contact us.

Technical characteristics

- Max. operating temperature: 200°C (392°F)
- Weight (standard pump) 4 kg (8.8 lbs)

Graphs (see page 12)

- Power consumption
- Flow as a function of output pressure

Example of setting, PBV56.5 pump.
For other settings, please contact us.

Power consumption at 3150 rpm

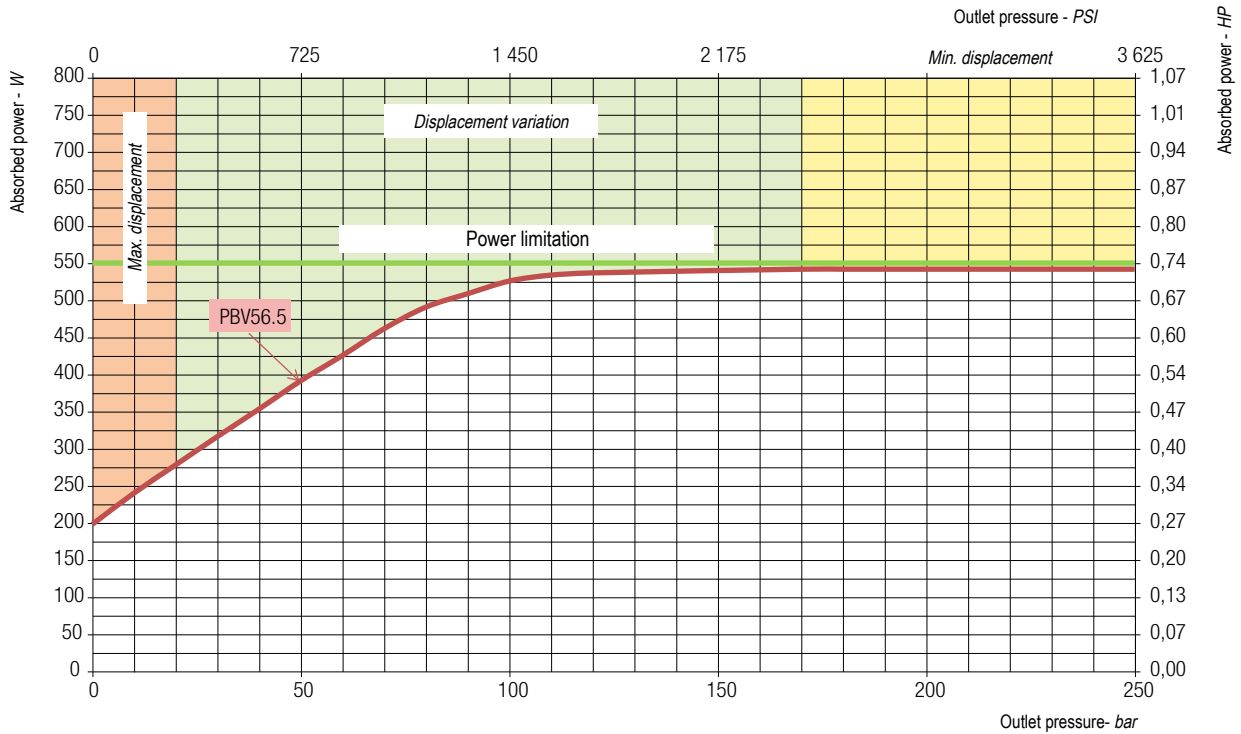

Flow as a function of outlet pressure at 3150 rpm

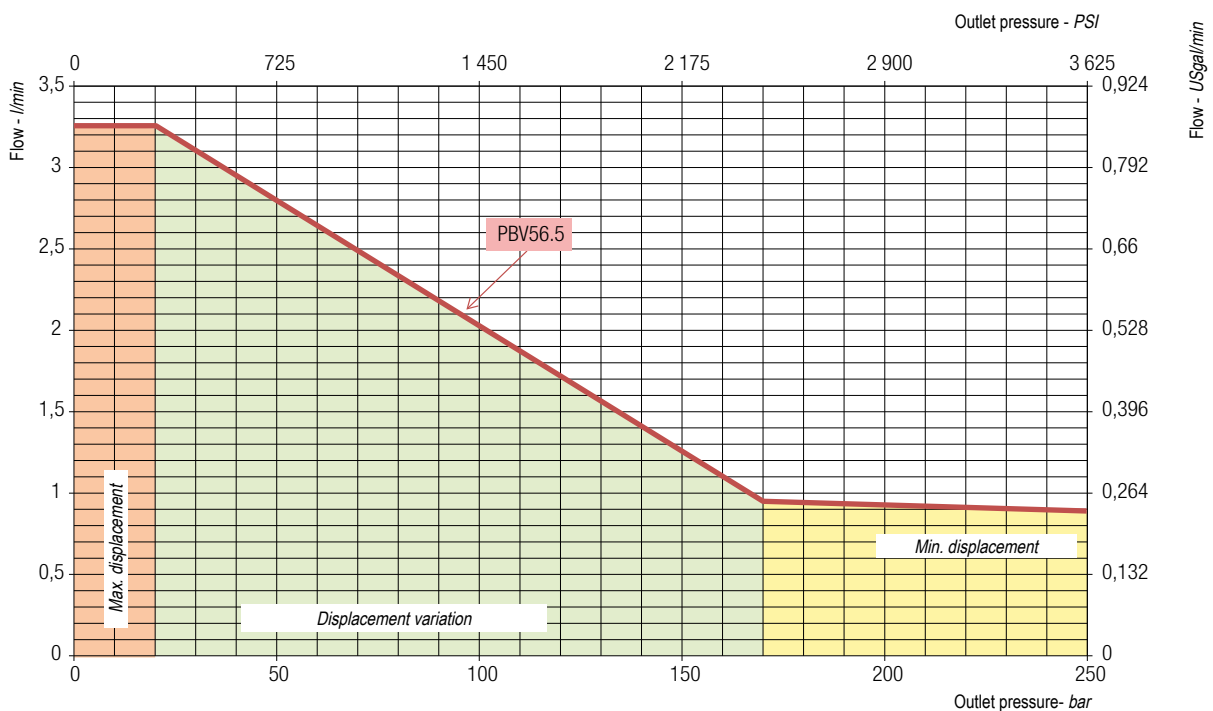

These graphs are the results of testwork done in the HL R&D laboratory, on a specific test bench. Viscosity of the fluid: 65 cSt.

Micro-hydraulic motor MH450 DS

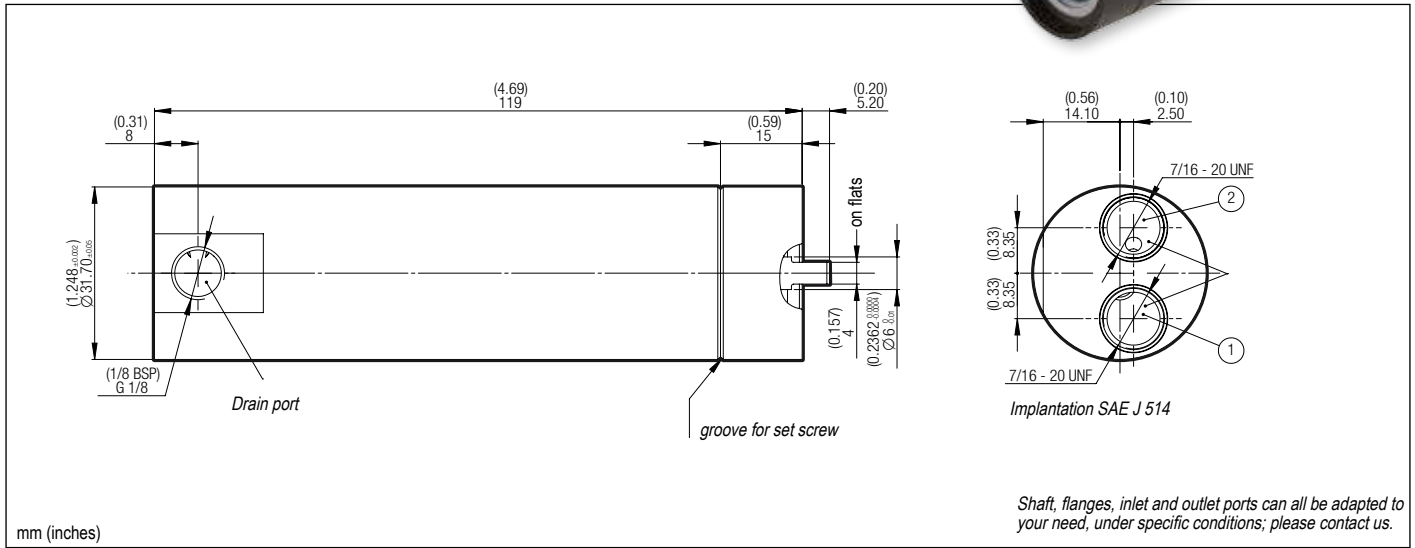

MOTOR WITH DUAL DIRECTION OF ROTATION

■ Characteristics

Motor type	Direction of rotation	Max. rotating speed (rpm)		Displacement		Max. pressure				Max. pressure on the drain line	
		mini	maxi	mm ³	Cu.in	continuous		peak		bar	PSI
MH450 DS	0521960 ①→② CW ②→① CCW	350	6500	463	0.0283	330	4780	400	5800	3	45

■ Technical characteristics

- Max. operating temperature: 150°C (302°F), and 175°C (347°F) peak (up to 5% of the time).
- Type of accepted fluids: hydraulic mineral oils, for other fluids please contact us.
- Weight: 0.7 kg (1.5 lbs)

■ Graphs (see page 14)

- Torque as a function of inlet pressure.
- Rotating speed as a function of inlet flow.

Micro-hydraulic motor MH450 DS

MH450DS / Torque as a function of inlet pressure

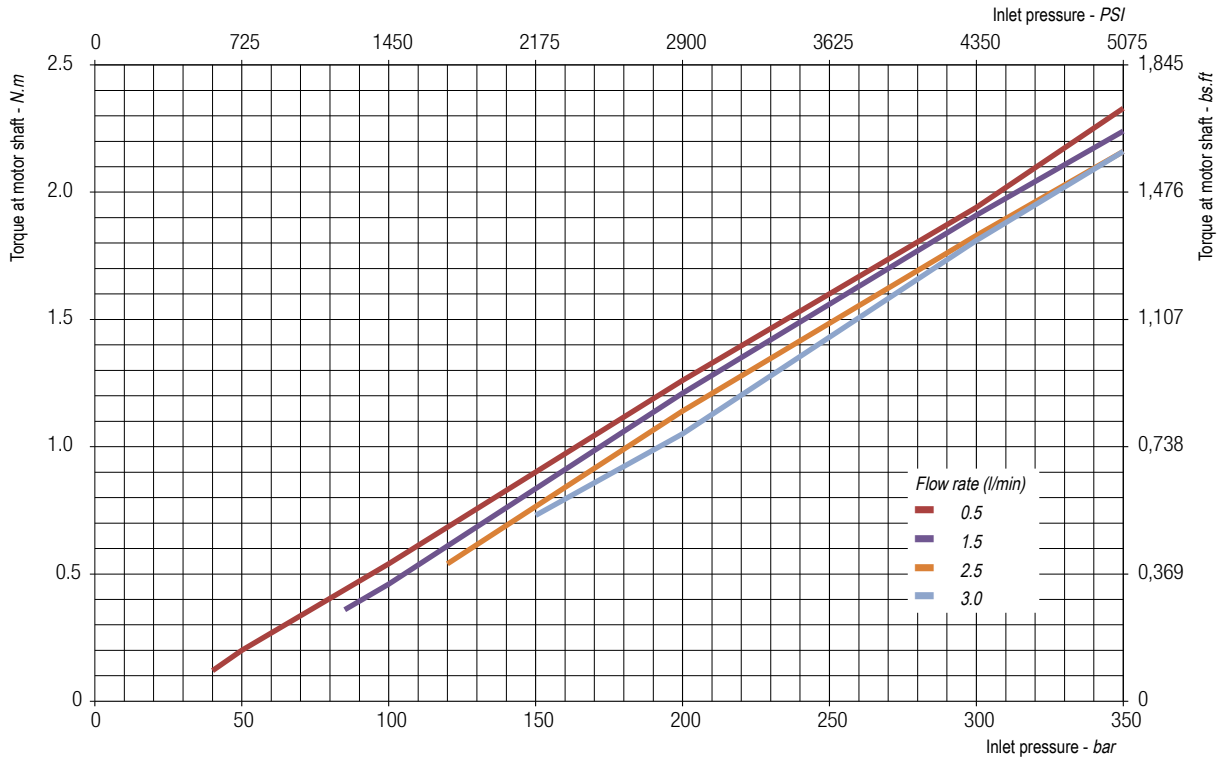

14

MH450DS / Rotating speed as a function of flow rate

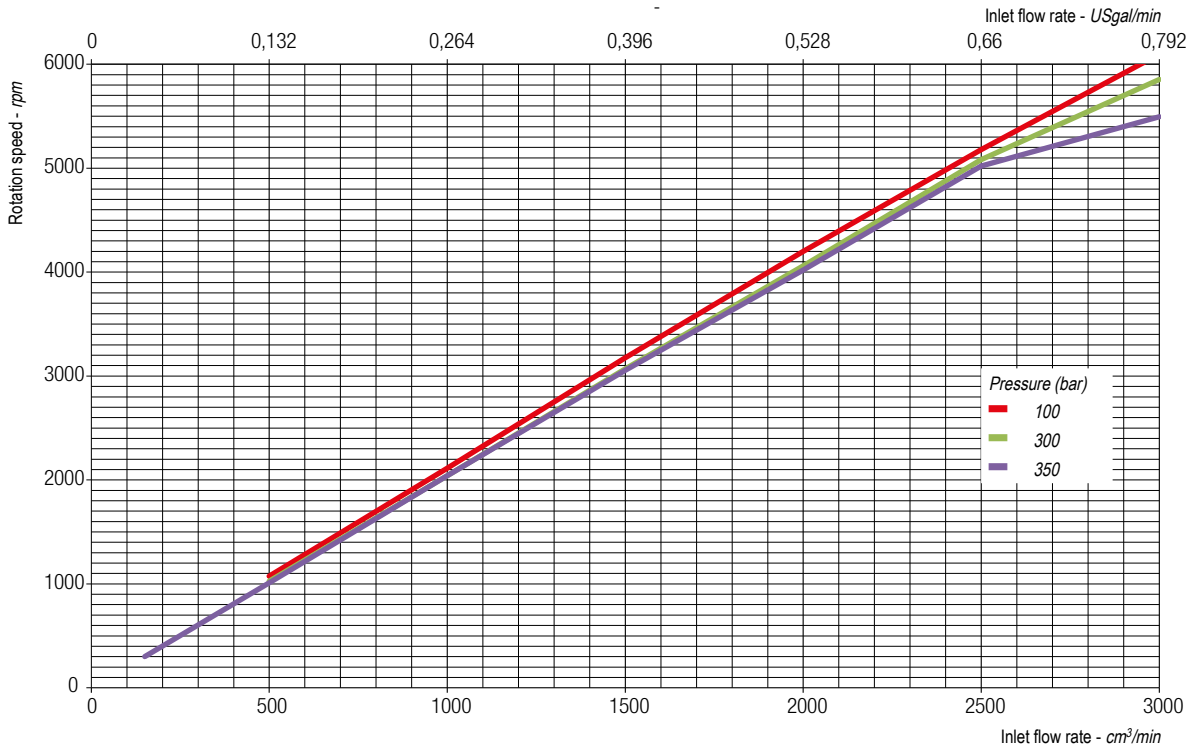

These graphs are the results of testwork done in the HL R&D laboratory, on a specific test bench. Viscosity of the fluid: 65 cSt.

Microhydraulics accessories

HYDRO LEDUC also offers a range of customized accessories adapted to your needs.

Check valve

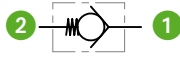

LEDUC code	0513690
Max. operating pressure	300 bar (4350 PSI)
Max. flow	2000 cm ³ /min (0.53 USgal/min)
Temperature range	-30°C to 200°C (-22°F to 392°F)

Viscosity	Q max		Reduced pressure drop Δ P	
	cm ³ /mn	USgal/min	bar	PSI
200 cSt	1550	0.41	3.80	55.1
	50	0.013	0.18	2.6
60 cSt	1550	0.41	1.00	14.5
	50	0.013	0.14	2.0
2 cSt	1550	0.41	0.35	5.0
	50	0.013	0.12	1.7

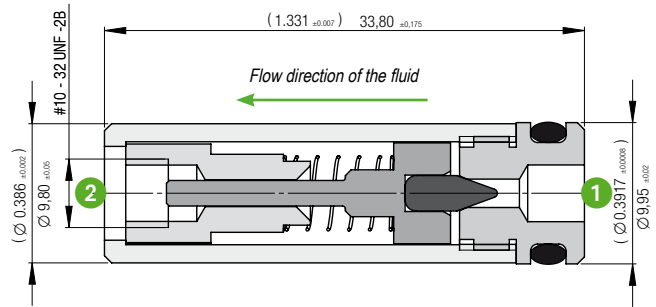

Example of cartridge assembly 0513690

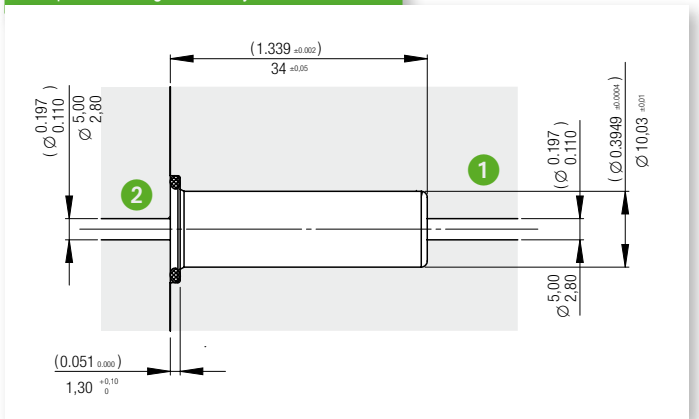

Miniature check valve



LEDUC code	0515080
Max. flow	1000 cm ³ /min (0.26 USgal/min)
Max. operating pressure	300 bar (4350 PSI)
Temperature range	-30°C to 200°C (-22°F to 392°F)

Viscosity	Q max		Δ P	
	cm ³ /mn	USgal/min	bar	PSI
200 cSt	800	0.21	45.6	661.3
	50	0.013	4.3	62.3
60 cSt	800	0.21	19.3	279.9
	50	0.013	0.5	7.2
2 cSt	800	0.21	4.6	66.7
	50	0.013	0.1	1.4

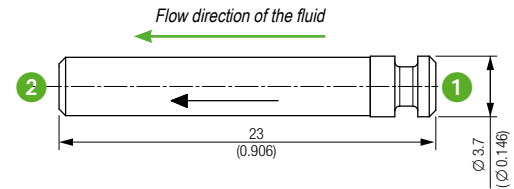

Example of cartridge assembly 0515080

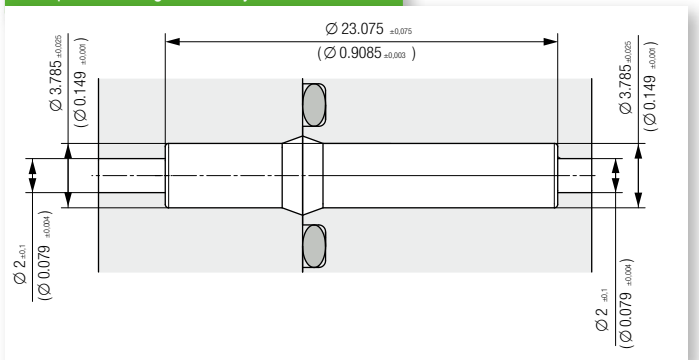

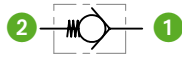

Relief valve maximum pressure 300 bar

LEDUC code	0513700
Max. flow	2000 cm ³ /min (0.53 USgal/min)
Opening pressure range	20 to 300 bar (290 to 4350 PSI)
Temperature range	- 30°C to 200°C (- 22°F to 392°F)

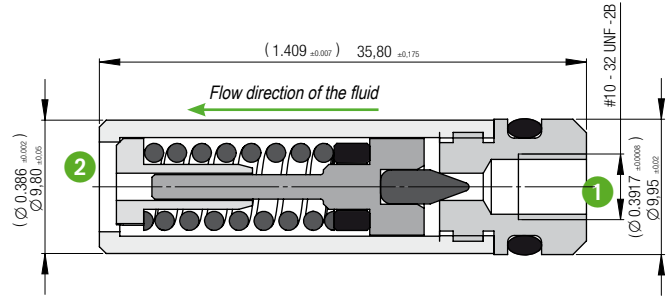

Example of 0513700 valves assembly

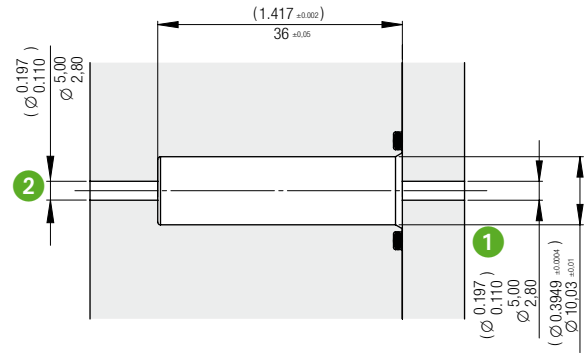

Complete functions

HYDRO LEDUC offers, on request, complete solutions to design and manufacture hydraulic power-packs incorporating pump, electric motor, valving, tank, relief valve, actuators etc., all to fit within your particular space envelope.

The hydraulic pump is at the heart of our know-how, but the R&D department also masters the technology of the surrounding components. This allows a wide choice of solutions, and custom-designed developments.

An efficient partnership with a highly skilled and experienced team will guarantee your requirements will be satisfied.

HYDRO LEDUC can integrate your solution by proposing the following services:

- Mechanical integration of YOUR components;
- Hydraulic integration (high and low pressure tubes, Purge and oil filling, fluid contamination control...);
- Electrical integration (wiring);
- Qualification and testing of the complete assembly by simulating your working conditions, in terms of temperature and ambient pressure.



Hydraulic power pack for oceanographic buoy

Pump-motor unit for oiltool



All micro-hydraulic pumps and units are tested individually on specific test benches, to guarantee performance. However, once in your application, guaranteeing performance depends on how well the following guidelines are adhered to. The following recommendations apply to both micro-pumps and micro-motors.

■ Before using a micropump

LEDUC micro-pumps are supplied in a storage fluid, to protect the components from corrosion. It is a mineral oil of general use, mixible in all proportions with most typical hydraulic fluids.

Before installing the micropump, simply empty the storage fluid, no rinsing required, then fill with your usual hydraulic fluid (chosen in line with our recommendations).

■ Direction of rotation

Most LEDUC micro-pumps are manufactured for a given direction of rotation.

The direction of rotation is always determined by looking at the pump shaft; it is engraved on the housing:

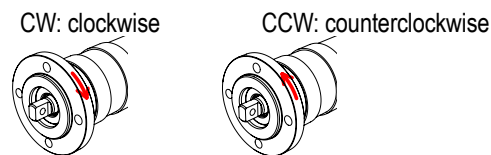

For those models made in one direction of rotation only, it is possible, on request, to produce the same pump for the other direction of rotation.

■ Fluids

Micro-hydraulic pumps and motors are generally used with mineral-based hydraulic fluids.

However, new fluids are also compatible with most LEDUC pumps and motors:

- Synthetic oils,
- Biological and biodegradable,
- Fluids with some water content.

LEDUC pumps and motors accept a wide range of viscosity. For extreme viscosity, the rotating speed and the inlet pressure of the pump must be adapted. Please ask our Technical Department.

Whatever fluid is used, it is essential, to ensure a controlled cleanliness class during the start-up.

We recommend the use of contamination class 15/14/12 according to ISO 4406 (equivalent to a class 6 according to standard NAS 1638 or lower).

For all special applications, please ask our Technical Department. To enable us to assist you in your choice and to optimize your microhydraulic installation, we will ask you to advise:

- The product will be required to operate at the working cycle (flow-pressure),
- Type of fluid, viscosity and operating temperature,
- Supply conditions (pressurization, design of inlet line),
- The drive mode.

■ Drive modes

Direct drive (pump directly flanged onto the motor) is always the preferred solution.

If another drive mode is used, please avoid any load on the pump shaft (axial or radial load).

Considering the specificity of these pumps, please contact our Technical Department to check your project feasibility.

■ Filtration

The cleanliness of the fluid is vital for hydraulic component, to run satisfactorily, and to allow optimal service life.

As well as using fluid of the right cleanliness class (ISO4406 15/14/12), we also recommend fitting a 3-10 µm filter on the return line.

LEDUC pumps can be supplied fitted with a 40micron protective screen, which avoids start-up accidents in cases where a contaminant (end of thread, tiny piece of hosing, flake of paint etc.) might get into the pump supply circuit.

■ Installation precautions

Carefully clean and rinse the tank and all pipes and hoses to remove any contaminants that could damage the installation.

■ Installation position (see figures at the bottom of the page)

Microhydraulic components can be used in any position. However, some installation positions can complicate the start-up (see the *start-up* part).

Horizontal position, submerged in oil (fig. 1): bleeding will happen naturally. After filling, wait several minutes before starting up.

Horizontal position, tank above the pump (fig.4): the pump will bleed itself in about one minute. Start up and run the pump slowly at first, until the air is purged from the fluid.

■ Supply line

The inlet line must be as direct as possible, and well dimensioned to avoid any pressure losses.

Avoid all curves that could cause the fluid flow to slow down, or cause an air trap.

Inlet line performance can be improved by pressurizing the tank.

HYDRO LEDUC's technical department can help you to design your inlet circuit.

■ Start-up

The pump must be filled with oil and the circuit bled before starting the pump. The best bleed procedure to guarantee pump priming is as follows:

- when possible, position are of the inlet ports facing up, to evacuate air;
- it is good to turn the pump slightly during bleeding process, to displace the air pockets which may have formed during filling;
- initial start-up should be at low speed (around 500 rpm). If this is not possible (constant speed motor), operate on/off intermittently.
- initial start-up must be without load on the bearing. Then apply load gradually if possible.

HYDRO LEDUC can fit its pumps with a self-priming system, adapted to difficult operating conditions (vertical position, risk of interruption of supply flow...). Please ask us.

■ Checking inspection

On start-up, check oil outlet flow is constant and regular. Fluid must not be emulsified, if it is, restart purge process.

■ Maintenance

LEDUC pumps do not require any particular maintenance and are designed to ensure long service life. However, the fluid in the circuit should be changed every 500 to 1000 hours of operation (depending on the contamination and the type of fluid).

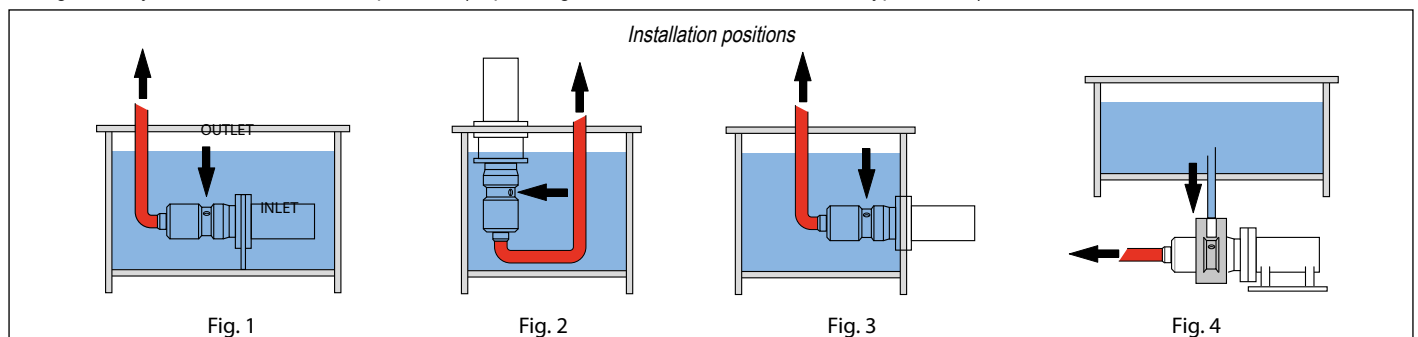

other product lines

hydraulic motors

Fixed displacement bent-axis piston motors. Models from 5 to 180 cc (0.3 to 11 Cu.In). Available both in ISO and SAE versions.

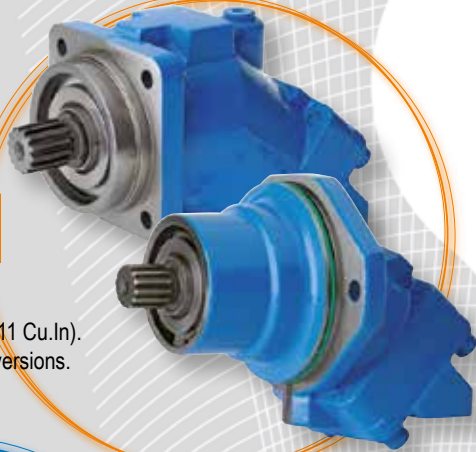

mobile and industrial pumps

Fixed displacement pumps, the W series, and variable displacement pumps, the DELTA series. High pressure capabilities within minimal size.

W series: flanges to ISO 3019/2, shafts to DIN 5480.
DELTA series: SAE shafts and flanges.



hydro-pneumatics

accumulators

Bladder, diaphragm and piston accumulators. Spherical and cylindrical accumulators. Volume capacities from 1.22 Cu.In to 13.21 gallons (20 cc to 50 liters). Pressures up to 7250 psi (500 bar). Accessories for use with hydraulic accumulators.

TXV

XP

PA PAC PAD

piston pumps for trucks

HYDRO LEDUC offers 3 ranges of piston pumps perfectly suited to all truck, construction equipment, and PTO-mount applications. Fixed and variable displacement from 12 to 150 cc (0.73 to 9.25 Cu.In).

micro-hydraulics

This is a field of exceptional HYDRO LEDUC know-how:

- axial and radial piston pumps, of fixed and variable displacement,
- axial piston micro-hydraulic motors,
- micro-hydraulic units incorporating pump, electric motors, valving, controls, etc.

To users of hydraulic components which have to be housed in extremely small spaces, HYDRO LEDUC offers complete, original and reliable solutions for even the most difficult environments.



we are passionate
about hydraulics...

 **HYDRO
LEDUC**

A dedicated R&D team means HYDRO LEDUC is able to adapt or create products to meet specific customer requirements. Working in close cooperation with the decision-making teams of its customers, HYDRO LEDUC optimizes proposals based on the specifications submitted.

a passion for hydraulics

HYDRO LEDUC

Head office and Factory
BP 9 - F-54122 AZERAILLES (FRANCE)
Tél. +33 (0)3 83 76 77 40 - Fax +33 (0)3 83 75 21 58

HYDRO LEDUC GmbH

Haselwander Str. 5
D-77746 SCHUTTERWALD (GERMANY)
Tel. +49 (0) 781-9482590 - Fax +49 (0) 781-9482592

HYDRO LEDUC AB

Betongvägen 11
461 38 TROLLHÄTTAN - SWEDEN
Tel. 46 (0) 520 10 820

HYDRO LEDUC N.A., Inc.

19416 Park Row - Suite 170
HOUSTON, TEXAS 77084 (USA)
Tel. +1 281 679 9654 - Fax +1 832 321 3553

Complete catalogues available at:
www.hydroleduc.com



 **HYDRO
LEDUC**
make it simple

HYDRO LEDUC

SAS with capital of 4 065 000 euros

Siret 319 027 421 00019

RC Nancy B 319 027 421